

# USER MANUAL

## VEGAS-S

### DATA DIODE

**PART NUMBER:  
NW-1553-DD-VS01**



*Trusted RF Solutions™*



NuWaves Engineering  
132 Edison Drive  
Middletown, Ohio 45044  
Tel: 513-360-0800  
[www.nuwaves.com](http://www.nuwaves.com)  
[product.sales@nuwaves.com](mailto:product.sales@nuwaves.com)

## 1 VEGAS-S OVERVIEW

The Vegas-S data diode provides security when accessing MIL-STD-1553 data busses. Offered in a ruggedized chassis, the module is ready for both lab and in-flight use. Acting as a physical firewall between the MIL-STD-1553 avionics bus and LRUs, this controlled data flow offers true risk mitigation to the aircraft's avionics bus. Serving not only the data diode function, Vegas-S users also benefit from the modules ability to recondition signals on the data bus thus protecting the data against signal transients, while also benefiting from increased signal range (up to an additional 200ft of MIL-STD-1553 cabling).

To assist users of the Vegas-S product, interface cable part number CYB-CBL-02-F is available as a purchase option.

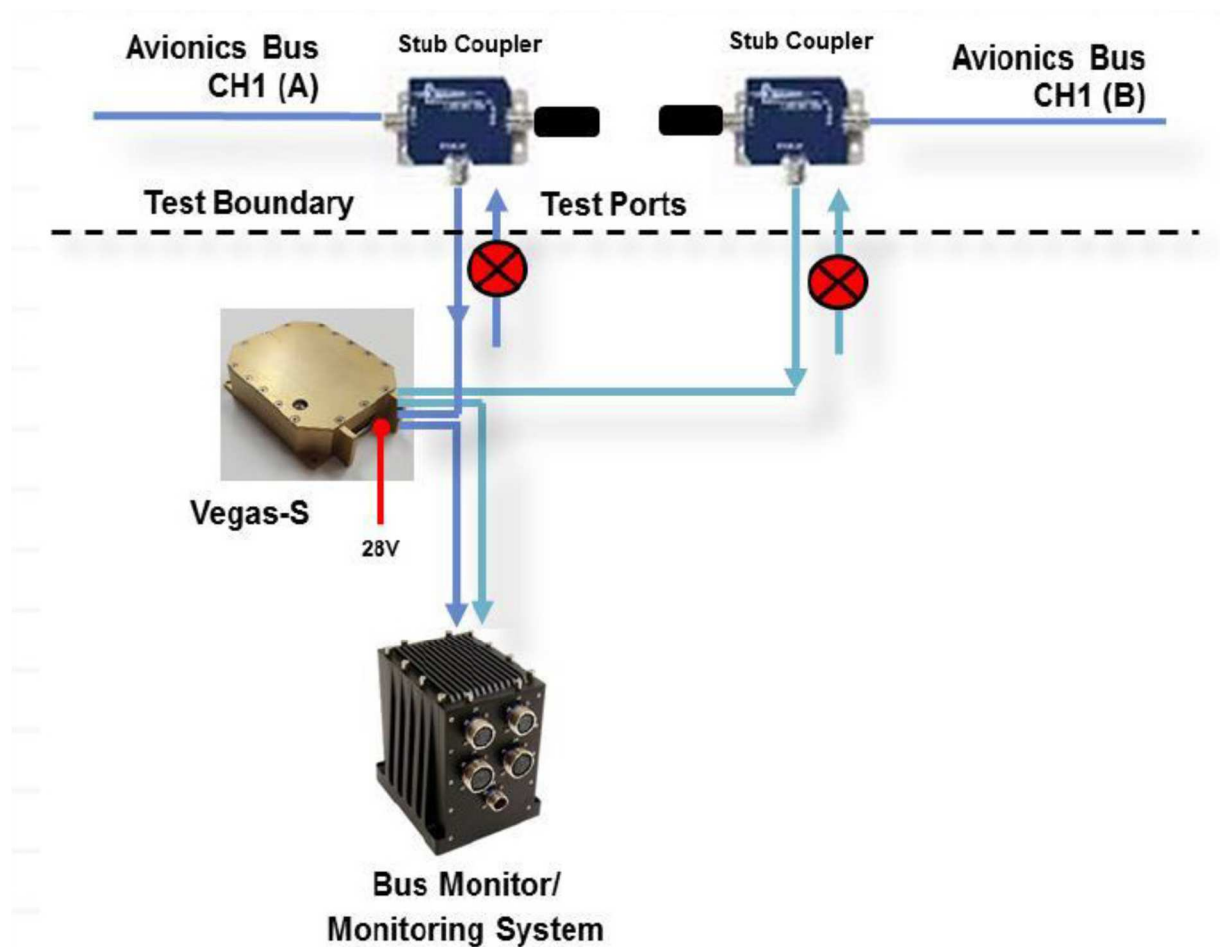

Figure 1: Vegas-S Typical System Implementation

## VEGAS-S PERFORMANCE HIGHLIGHTS

Performance highlights of the Vegas-S module are outlined in Table 1.

**Table 1: Vegas-S Performance Highlights**

Design Characteristic	Benefit
Current	40 mA
Input Voltage	28 VDC
Design Simplicity	No loadable firmware or software, single chip solution
Latency	Low input to output latency (200 ns)
Ruggedized Design	Tested to an array of MIL-STD-810G, MIL-STD-704F, and MIL-STD-461G tests
Transient Signal Protection	Protects against voltage transients while also reconditioning data signals
Extended Range	Offers extended range of up to 200 ft of MIL-STD-1553 cabling
Data Diode	Protects avionics bus from malicious attack through physical hardware

---

## 2 VEGAS-S FUNCTIONAL DESCRIPTION

---

The Vegas-S physically hardwires MIL-STD-1553 transceivers to maintain one-way data flow. LRUs can therefore only receive commands and messages, and any attempt at a response is blocked from entering the rest of the data bus system. All erroneous or malicious messages originating in a compromised LRU are halted at the Vegas-S module.

No software or firmware is present in the Vegas-S module.

The inset Number 2 screw in the lid conceals a power indicator LED. To confirm proper power input to the module, remove inset screw. An illuminated LED (color blue) signifies power supplied to the module is appropriate.

## INTERFACE DEFINITIONS

The connector pin-out definitions for the module's connector are provided in Table 2. In a typical installation, the Vegas-S module is mated to a MIL-STD-1553 data bus and power supply via an interface cable. Figure 2 shows the connector pin numbers, as viewed from the front of the module.

**Table 2: Vegas-S Pin-Out Definitions**

Pin Number	Pin Name	I/O	Description
2	CH 3 Low	O	MIL-STD-1553 Low Channel 3
4	CH 3 High	O	MIL-STD-1553 High Channel 3
5	CH 2 Low	I	MIL-STD-1553 Low Channel 2
7	CH 2 High	I	MIL-STD-1553 High Channel 2
9	CH 4 Low	I	MIL-STD-1553 Low Channel 4
10	CH 4 High	I	MIL-STD-1553 High Channel 4
1, 3, 6, 8	GND	I	DC Ground.
11	+28 VDC	I	DC Supply Voltage, +28 Volts.
12, 13	28 VDC Return	O	DC Supply Voltage, Return
14	CH 1 Low	O	MIL-STD-1553 Low Channel 1
15	CH 1 High	O	MIL-STD-1553 High Channel 1

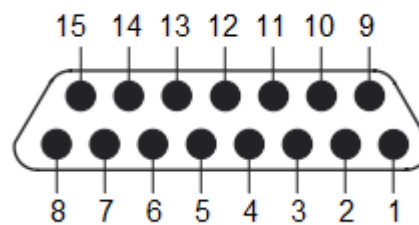

**Figure 2: Vegas-S Connector Pin-Out**

## INTERFACE CABLE (PURCHASE OPTION)

The 36" shielded interface cable is comprised of a 15 pin micro-D connector on one end, and four MIL-STD-1553 connectors and one power connector on the opposite end. This cable provides input power to the Vegas-S module and allows interfacing with the MIL-STD-1553 data bus.

Channel 1 on the interface cable is a MIL-STD-1553 output, and Channel 2 is the corresponding input. Channel 3 is an additional output, with Channel 4 the corresponding input. On the power connector, the pin labeled "30 VOLTS" is the positive pin. The pin labeled "NEMA FSL1" is the ground pin. Figure 3 shows NuWaves part number CYB-CBL-02-F.

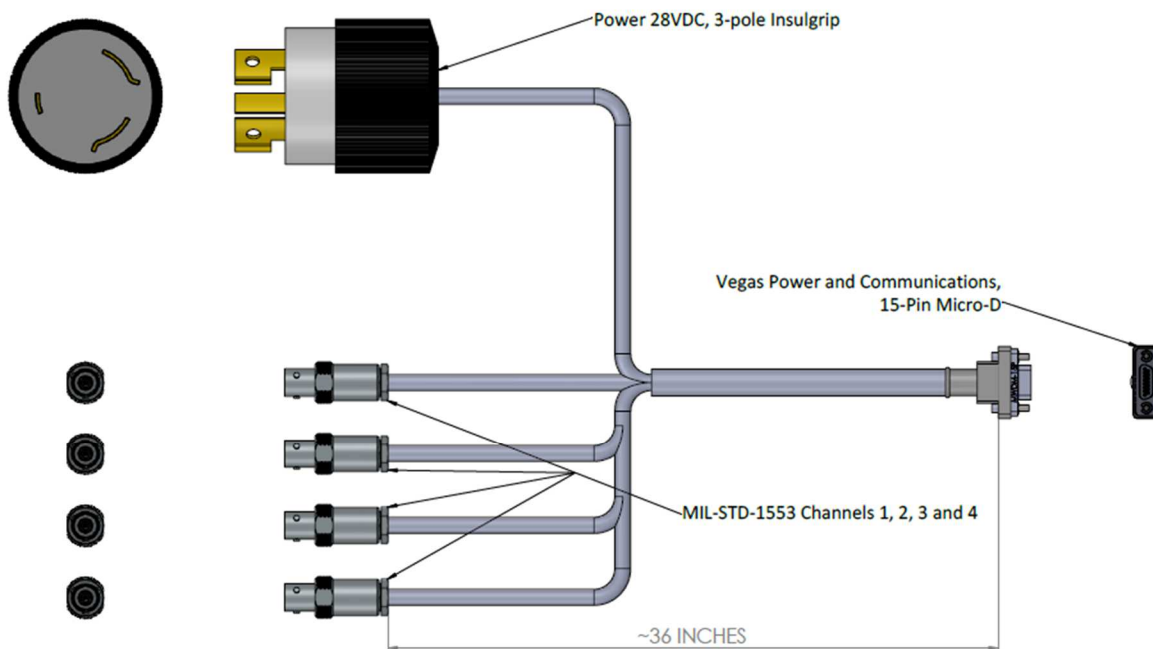

Figure 3: CYB-CBL-02-F Vegas-S Interface Cable

### 3 MECHANICAL

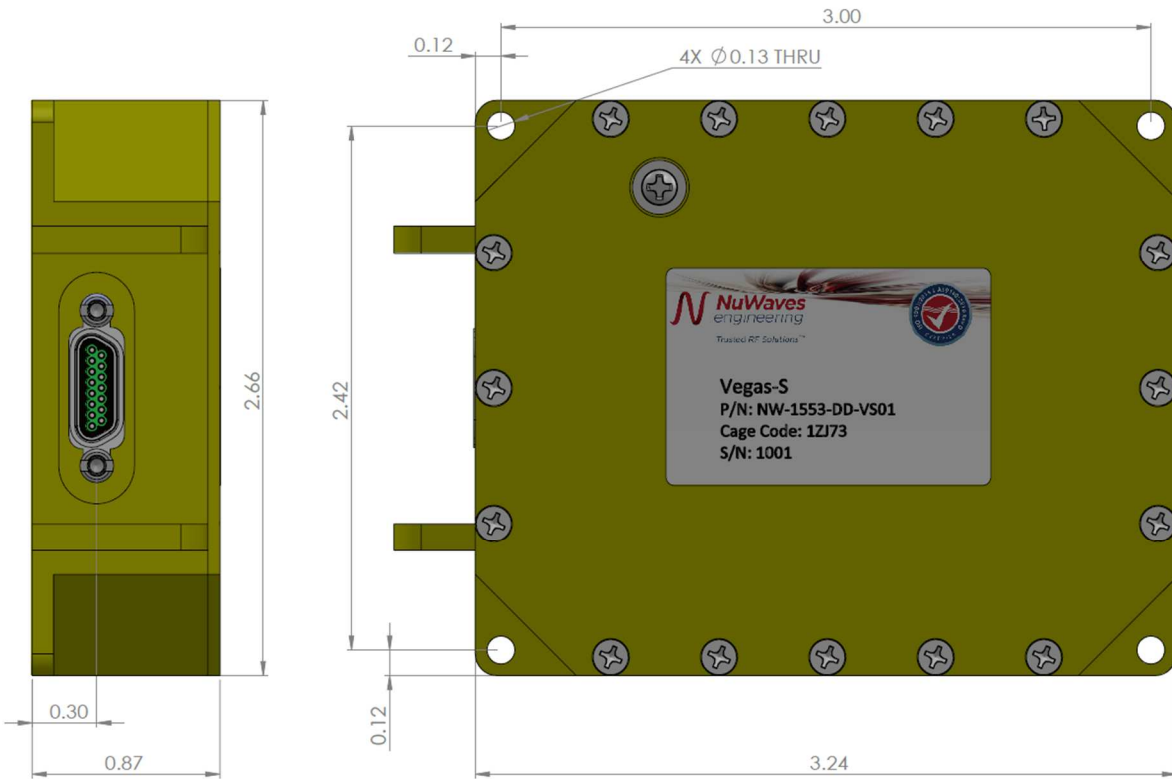

Figure 4: Vegas-S Mechanical Outline

Table 3: Vegas-S Mechanical Specifications

Parameter	Specification
Interface Connector	15 Pin Micro-D
Dimensions (LxWxH)	3.24" x 2.66" x 0.87"
Weight	0.5 lbs

---

## 4 PRODUCT DISPOSAL – END-OF-LIFE

---

Safety is a guiding principle of NuWaves Engineering. We ensure safe production and operation of our products, as well as end-of-life disposal. Improper disposal can adversely affect the environment, wildlife and human health. Please follow these guidelines when disposing of a NuWaves product:

- Do not remove the cover or any hardware
- Do not remove components from the circuit card assembly
- Do not incinerate
- Do not crush or shred
- Do not dispose of as unsorted municipal waste
- Do not export e-waste outside of the original destination country for recycling
- Utilize an e-Steward or ISO14001 certified e-waste recycler
- Consider export controls during recycler selection
- If a NuWaves product is incorporated into a larger system or sub-system, ensure that these guidelines are followed at system end-of-life

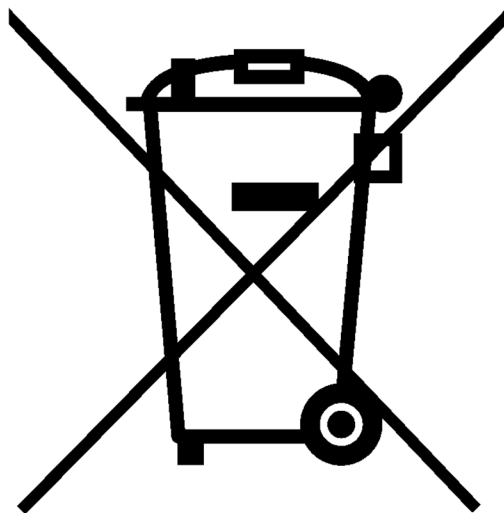

---

## 5 GETTING HELP - APPLICATIONS ENGINEERING

---

NuWaves Engineering offers technical support for basic configuration help and troubleshooting, Monday through Friday, 8 a.m. to 5 p.m. Eastern Time.

Technical Assistance and Application Engineering:

Email: [product.sales@nuwaves.com](mailto:product.sales@nuwaves.com)

Phone: (513) 360 - 0800

NuWaves Home Page: <https://www.nuwaves.com/>

Product Warranty:

[https://products.nuwaves.com/wp-content/uploads/NuWaves\\_Warranty\\_Repair.pdf](https://products.nuwaves.com/wp-content/uploads/NuWaves_Warranty_Repair.pdf)

---

## GENERAL INFORMATION

---

Copyright © 2006 – 2020 NuWaves Ltd. All rights reserved. The information contained in this user manual is copyright protected. NuWaves reserves the right to make periodic modifications and product improvements to the Vegas-S product line and the associated documentation.