

# NuWaves

## RF Solutions

### VEGAS-429 ARINC 429 Data Diode Supports 8 Channels

P/N: NW-429-DD-VS01

(U.S. Patent 10,432,730)



#### **The Vegas-429 Data Diode was created for the ARINC 429 avionics bus.**

Vegas-429 allows for the isolation of the main ARINC 429 avionics bus from bus monitors or systems under test for enhanced safety of flight. This control of data flow over the ARINC 429 bus provides true risk reduction to the aircraft's avionics bus for early software upgrades to existing bus monitoring systems, along with reducing the risk to the aircraft's avionics bus for early bus monitor integration. Vegas-429 supports eight independent ARINC 429 channels. Each channel has its own differential input and differential output. Each unit comes in a 35 in<sup>3</sup> / 0.94 lb package offering 40 mA at 28VDC.

#### **Protect your vital information by using the Vegas-429 ARINC 429 Data Diode from NuWaves RF Solutions.**

##### Features

- Simple single chip solution
- No loadable software or firmware
- No microcontrollers or processors that could be maliciously altered
- Very low input to output latency
- Protects avionics bus from malicious traffic
- Protect against an LRU failure or voltage transient
- Subjected to MIL-STD-810G, MIL-STD-704F, and MIL-STD-461G tests
- Hardware Switch Adjustable transmission rate

##### Benefits

- Acts as a physical firewall
- Cleans up signals on the bus, and protects against signal transients
- Alternative to untrusted monitors
- Reconditions the ARINC 429 signal for driving at least 200 feet of ARINC 429 cable
- Simplifies cyber assessment and authorization

##### Applications

- Protects avionics bus from untrusted commercial-off-the-shelf (COTS) bus monitors
- Protects avionics bus from roll on/off equipment
- Protects the avionics bus from traffic insertion at open test ports on aircraft
- Acts as a repeater to extend the length of the avionics bus

# VEGAS-429 ARINC 429 Data Diode

## Specifications

Parameter	Rating	Unit
Max Device Voltage	30	V
Max Current @28VDC	100	mA
Max Storage Temperature	+85	°C

Export Classification
EAR99

## Electrical Specifications

Parameter	Symbol	Min	Typ	Max	Unit	Condition
Operating Voltage	VDC		28		V	
Operating Current	$I_{DD}$		80		mA	
Propagation Delay			200		ns	Input to Output
Speed Control (Low / High)			(12.5 / 100)		kHz	

## Mechanical Specifications

Parameter	Value	Unit	Limits
Dimensions (L x W x H)	6.00x3.00x1.96	in	Max
Weight	15	oz	
Interface Connector	D38999/20WD35PN		

## Environmental Specifications

Parameter	Symbol	Min	Typ	Max	Unit
Operating Temperature (ambient)	$T_A$	-55		+71	°C
Storage Temperature	$T_{STG}$	-55		+85	°C
Relative Humidity (non-condensing)	RH			95	%
Altitude MIL-STD-810G - Method 500.4	ALT			60,000	ft

## Vibration Figure

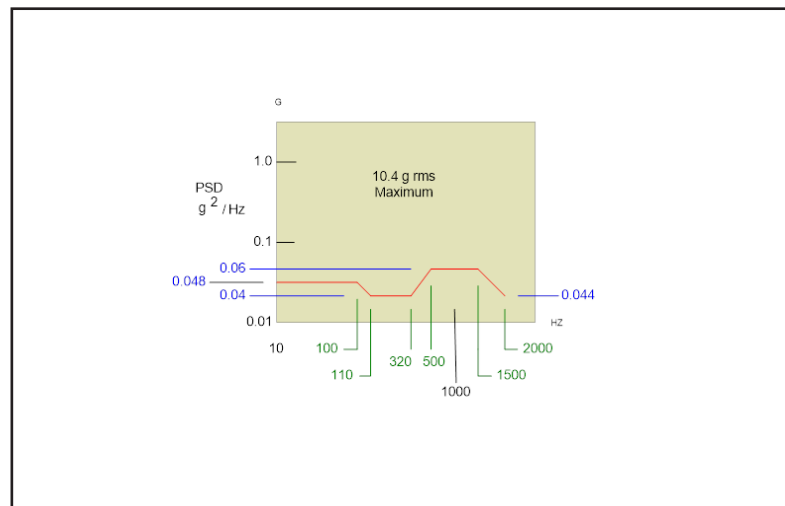

# VEGAS-429 ARINC 429 Data Diode

## Mechanical Outline

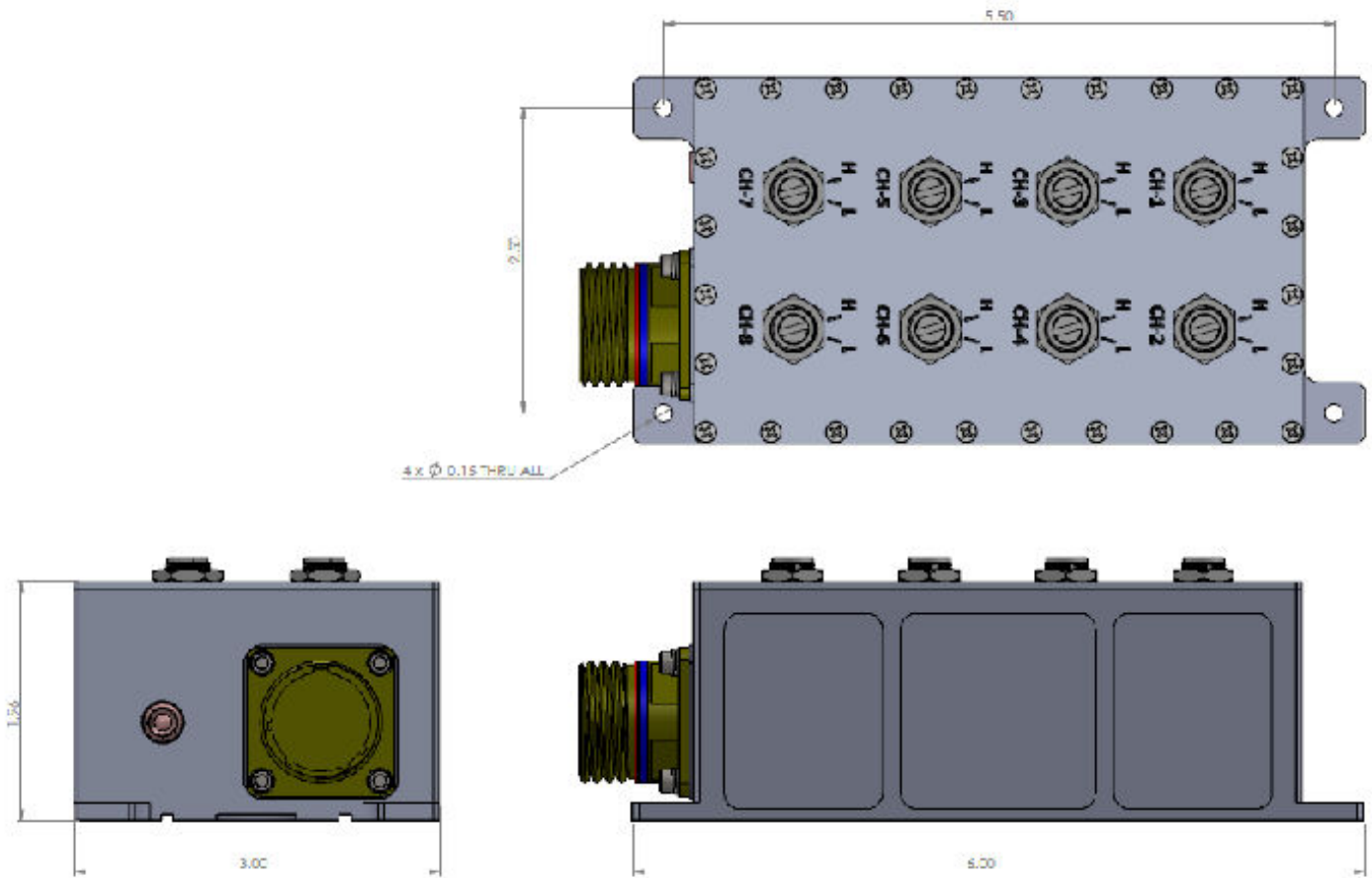

## Vegas Implementation

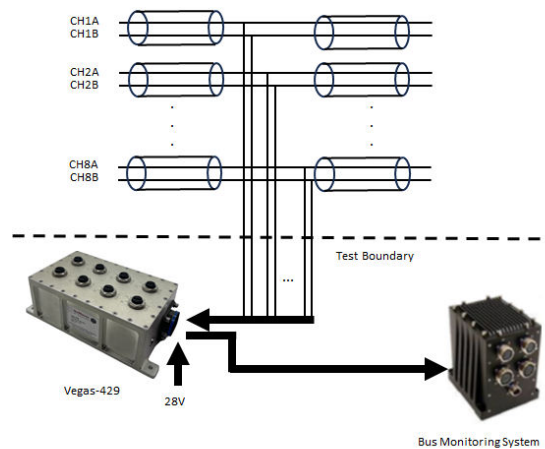

# VEGAS-429 ARINC 429 Data Diode

## MIL-STD Test Compliance

### MIL-STD-810G.

- 500.5 – Low Pressure (Altitude)
- 501.5 – High Temperature
- 502.5 – Low Temperature
- 507.5 – Humidity
- 511.5 - Explosive Atmosphere
- 514.6 – Vibration
- 516.6 Procedure 1 – Functional Shock
- 516.6 Procedure 5 – Crash Hazard Shock

### MIL-STD-461G.

- CE101 – Conducted emissions
- CE102 – Conducted emissions
- CS101 – Conducted susceptibility
- CS114 curve 5 – Conducted susceptibility
- CS115 – Bulk Cable Injection, Impulse Excitation
- CS116 - Conducted Susceptibility, Damped Sinusoidal Transients

CS118 – Personnel Borne Electrostatic Discharge (ESD)

RE101 – Radiated emissions

RE102 – Radiated emissions

### MIL-STD-704F.

- LDC101 - Load Measurement
- LDC102 - Steady State Limits for Voltage
- LDC103 - Voltage Distortion Spectrum
- LDC105 - Normal Voltage Transients
- LDC201 - Power Interrupt
- LDC301 - Abnormal Steady State Limits for Voltage
- LDC302 - Abnormal Voltage Transients (Over/Under voltage)
- LDC401 - Emergency Limits for Voltage
- LDC501 - Starting Voltage Transients
- LDC601 - Power Failure

\* Module has tested compliant to each test identified. Certified test results can be acquired per request based on unique implementation requirements.

## Accessory Part Numbers - Sold Separately

Part Number	Description
CYB-CBL-03-B	Vegas-429 External Interface Cable

### Pinout (PIN 2 is N/C)

PIN	Signal	PIN	Signal	PIN	Signal	PIN	Signal
1	Channel 2 (IN) A	11	Channel 3 (OUT) B	20	Channel 5 (IN) B	29	Channel 8 (OUT) A
3	Channel 5 (IN) A	12	Channel 3 (IN) B	21	+28VDC	30	Channel 2 (OUT) B
4	+28VDC	13	Channel 4 (OUT) B	22	Channel 5 (OUT) A	31	Channel 6 (IN) A
5	GROUND	14	Channel 4 (IN) B	23	Channel 6 (OUT) B	32	Channel 5 (OUT) B
6	GROUND	15	Channel 4 (IN) A	24	Channel 7 (IN) B	33	Channel 1 (OUT) A
7	Channel 6 (OUT) A	16	Channel 8 (IN) B	25	Channel 3 (OUT) A	34	Channel 1 (OUT) B
8	Channel 7 (IN) A	17	Channel 8 (IN) A	26	Channel 3 (IN) A	35	Channel 1 (IN) B
9	Channel 7 (OUT) A	18	Channel 2 (IN) B	27	Channel 4 (OUT) A	36	Channel 6 (IN) B
10	Channel 7 (OUT) B	19	Channel 2 (OUT) A	28	Channel 8 (OUT) B	37	Channel 1 (IN) A

For information on product disposal (end-of-life), please refer to this document:  
<https://nuwaves.com/wp-content/uploads/Product-Disposal-End-of-Life.pdf>

## Contact NuWaves



NuWaves RF Solutions  
132 Edison Drive  
Middletown, OH 45044

[www.nuwaves.com](http://www.nuwaves.com)  
[sales@nuwaves.com](mailto:sales@nuwaves.com)  
513.360.0800

