



Preliminary NuPower ULSC-20-C01-S01 Ultra Broadband Power Amplifier

500 MHz - 6.0 GHz

TX: 20 Watts RF Output Power (typ)

P/N: NW-PA-ULSC-20-C01-S01

(includes PA-CBL-06-F external interface cable with flying leads)

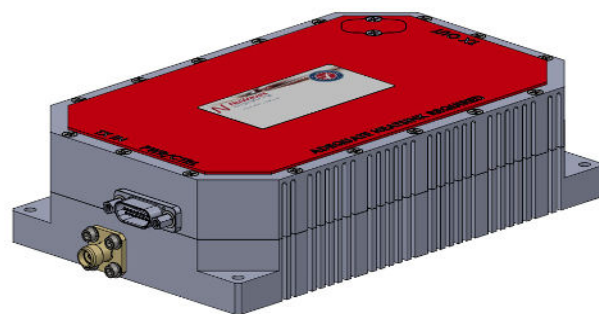

The NuPower™ ULSC-20-C01-S01 is a small, lightweight, and efficient Solid State Power Amplifier (SSPA) ideal for extending the communication range of wideband transceivers. The ULSC-20-C01-S01 PA generates 20 watts (typ) of RF power from 500 MHz to 6 GHz.

The high efficiency and compact form factor of the NuPower™ ULSC-20-C01-S01 PA makes it ideal for size, weight, and power-constrained RF telemetry and communication systems. This solid state PA features a compact form-factor, allowing the system integrator to easily incorporate the unit into the communications payload of unmanned aircraft systems (UAS) or other small to medium-sized platforms.

Extend your operational communication range with NuPower™ amplifiers from NuWaves RF Solutions.

Features

- 500 MHz to 6 GHz Operation
- 20 Watts (typ) RF Output Power
- 38 dB (typ) of Power Gain
- Small form factor optimized for size, weight, and power (SWaP)
- High Efficiency GaN Technology
- Over-Voltage & Reverse-Voltage Protection
- Non-proprietary interfaces
- MIL-STD-704F 28 VDC Compliant
- MIL-STD-461F CS101, CS114-116, RS103, RE102, CE102 Compliant

Applications

- Kratos DS-346 KestrelTWM Radio/SCISR
- Unmanned Aircraft Systems (UAS) - Group 2 and Group 3
- Small to medium-sized manned aircraft
- Airborne datalinks allowing ISR and command and control (C2) data transmission
- Remote video terminals (RTV)
- Unmanned Ground Vehicles (UGV)
- Lab Testing
- RF Communication Systems
- Software Defined Radios
- Counter UAS

Preliminary NuPower™ ULSC-20-C01-S01

Specifications

Absolute Maximums

Parameter	Rating	Unit
Max Device Voltage	30	V
Max Device Current	4	A
Max RF Input Power, $Z_L = 50 \Omega$, CW	15	dBm
Max Operating Temperature (ambient)	70	°C
Max Operating Temperature (baseplate)	85	°C

Export Classification
EAR99

Electrical Specifications @ 28 VDC, 25 °C, $Z_S=Z_L=50 \Omega$, CW, $P_{in} = +10$ dBm (unless specified otherwise)

Parameter	Min	Typ	Max	Unit	Condition
Operating Frequency	500		6000	MHz	
RF Output Power, P_{sat}		20		W	
Transmit Gain		38		dB	
Transmit Gain Flatness		± 3		dB	500 MHz to 6 GHz
Output Power @ 1dB Compression		25		dBm	500 MHz
		25			1875 MHz
		26			3250 MHz
		23			4625 MHz
		26			6000 MHz
Small Signal Gain		46		dB	500 MHz, @ -40 dBm Input
		44			1875 MHz, @ -40 dBm Input
		39			3250 MHz, @ -40 dBm Input
		42			4625 MHz, @ -40 dBm Input
		38			6000 MHz, @ -40 dBm Input
Small Signal Gain Flatness		± 10			$P_{in} = -40$ dBm; 500 MHz to 6 GHz
Operating Voltage	20	28	30	V	
Module Efficiency		30		%	
Transmit Input VSWR		2			
Nominal Input Drive Level		+10		dBm	
Quiescent Current (unbiased, No RF Signal Applied)		0.1		A	RF Enable OFF (N/C)
Quiescent Current (biased, No RF Signal Applied)		0.7		A	RF Enable ON (0V/GND)
Operating Current		2.6	4	A	
Third Order Intercept Point (Two tone test at 1MHz Spacing, $P_{out} = 20$ dBm/ tone)		38		dBm	500 MHz
		37			1875 MHz
		38			3250 MHz
		35			4625 MHz
		38			6000 MHz
Harmonics		-21		dBc	
		-26			
Output VSWR Mismatch (no damage)			10:1	Ψ	No damage at all phase angles

Preliminary NuPower™ ULSC-20-C01-S01

Mechanical Specifications

Parameter	Value	Unit	Limits
Dimensions	6.0 x 4.25 x 1.5	in	Max
Weight	30.0	oz	Max
RF Connectors, Input/Output	SMA Female		
Interface Connector	D-sub, 15-pin Socket		
Cooling	Adequate Heatsink Required		

Environmental Specifications

Parameter	Symbol	Min	Typ	Max	Unit
Operating Temperature (ambient)	T _A	-40		+70	°C
Operating Temperature (baseplate)	T _C	-40		+85	°C
Storage Temperature	T _{STG}	-55		+85	°C
Relative Humidity (non-condensing)	RH	5		95	%
Altitude MIL-STD-810F - Method 500.4	ALT			30,000	ft
EMI/EMC MIL-STD-461F CS101, CS114-116, RS103, RE102, CE102					
Blowing Dust Withstand MIL-STD-810F Section 510.4					
Fungal Growth Withstand MIL-STD-810F Section 508.5					
Operational Shock RTCA/DO-160E Section 7, 6g peak value for 11ms					
Operational Vibration RTCA/DO-160F Section 8, Category S, Curve M					
Non-Operational Vibration RTCA/DO-160F Section 8, Category S, Curve M					
Transportation Vibration MIL-STD-810F Section 514.5					
Endurance Vibration RTCA/DO-160F					

Performance Plots

Test Conditions: +28 VDC, +25 °C, Z_S=Z_L=50 Ω, CW, +10dBm Input Power (unless otherwise stated)

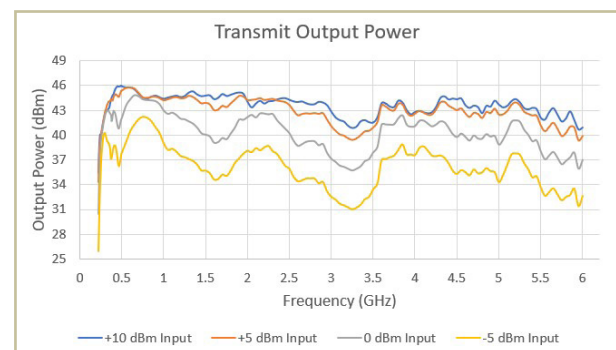
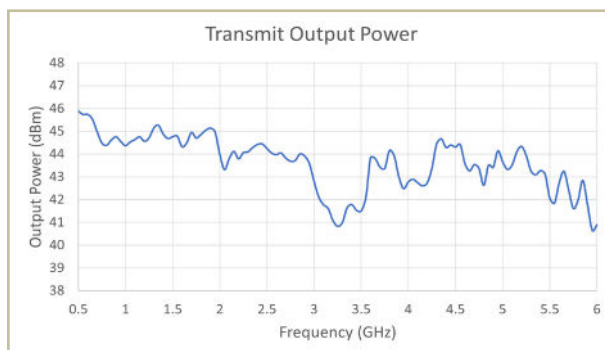

Preliminary NuPower™ ULSC-20-C01-S01

Performance Plots (cont.)

Test Conditions: +28 VDC, +25 °C, ZS=ZL=50 Ω, CW, +10dBm Input Power (unless otherwise stated)

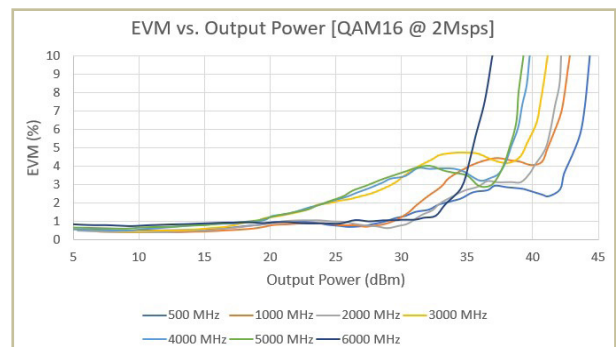
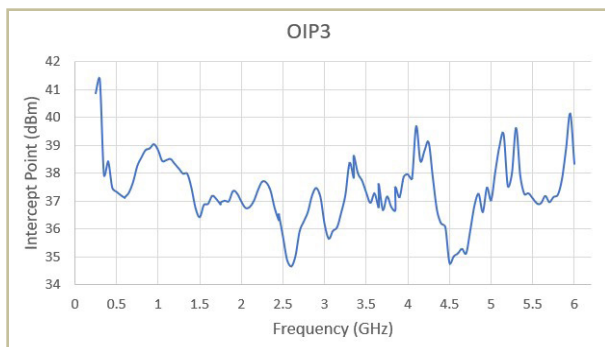
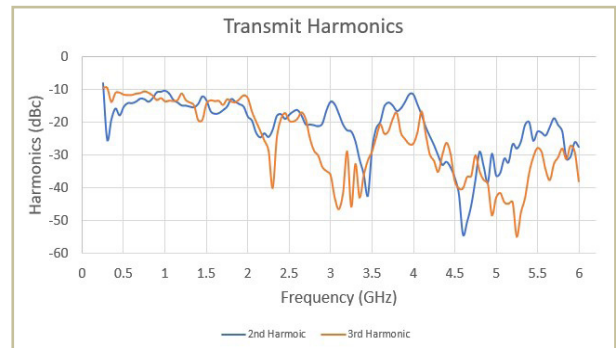
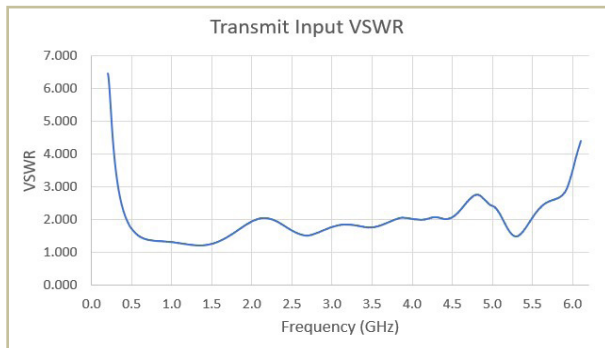
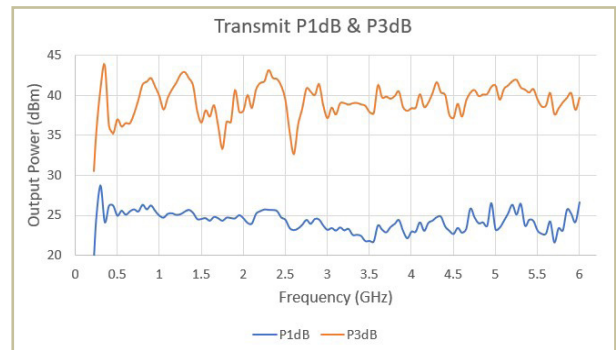
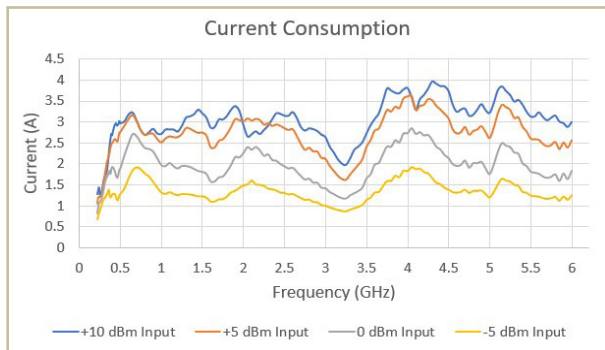
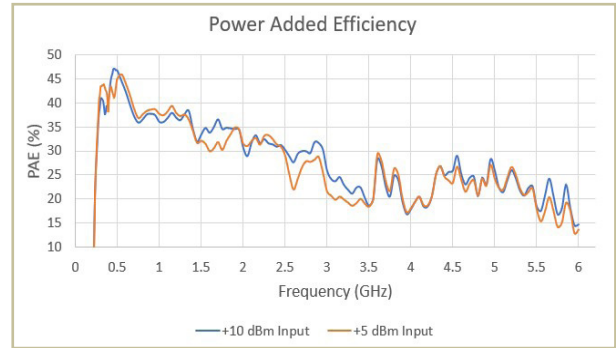
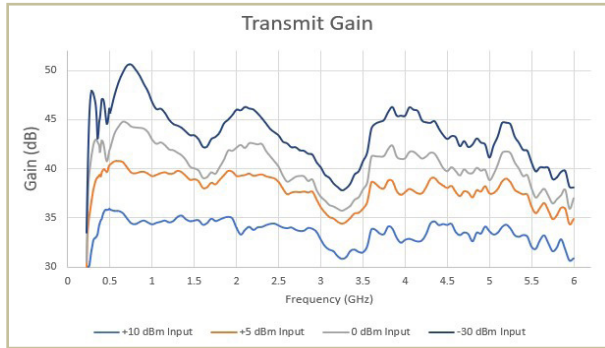

Preliminary NuPower™ ULSC-20-C01-S01

Mechanical Outline

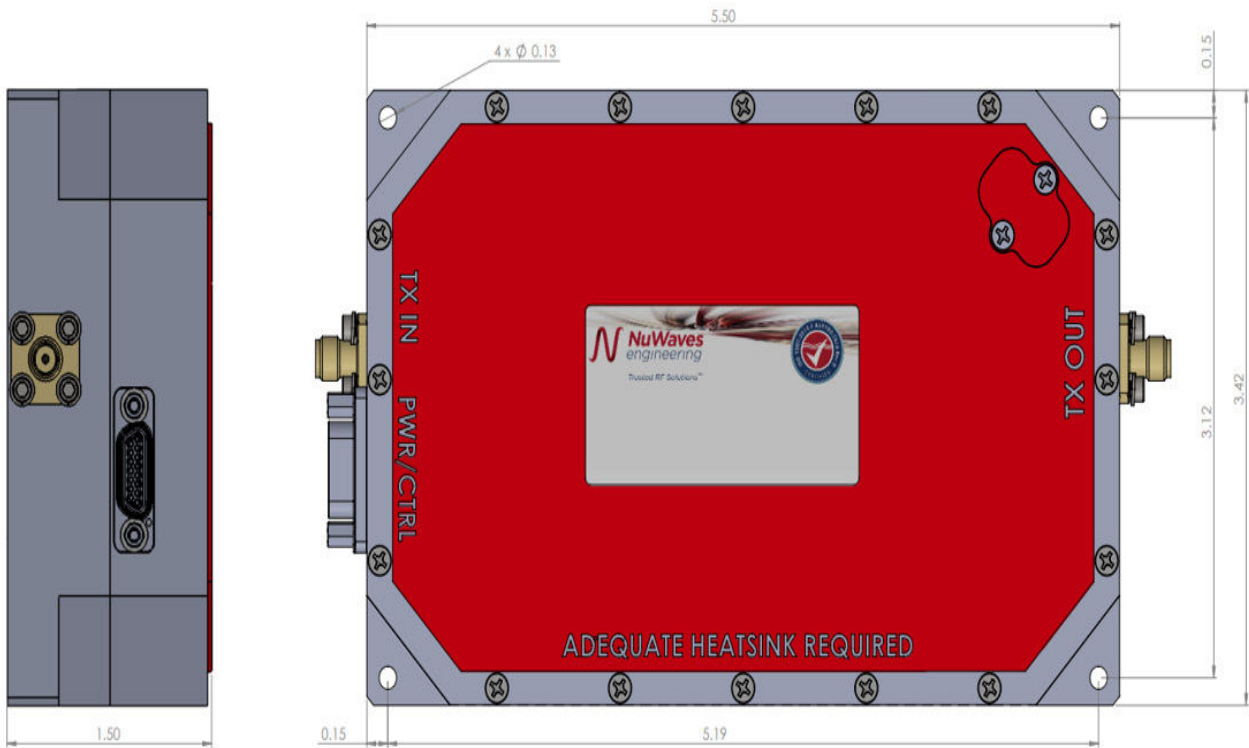

Preliminary NuPower™ ULSC-20-C01-S01

Optional Heatsink Drawing

Heatsink with Integrated Fan: HTSK-07

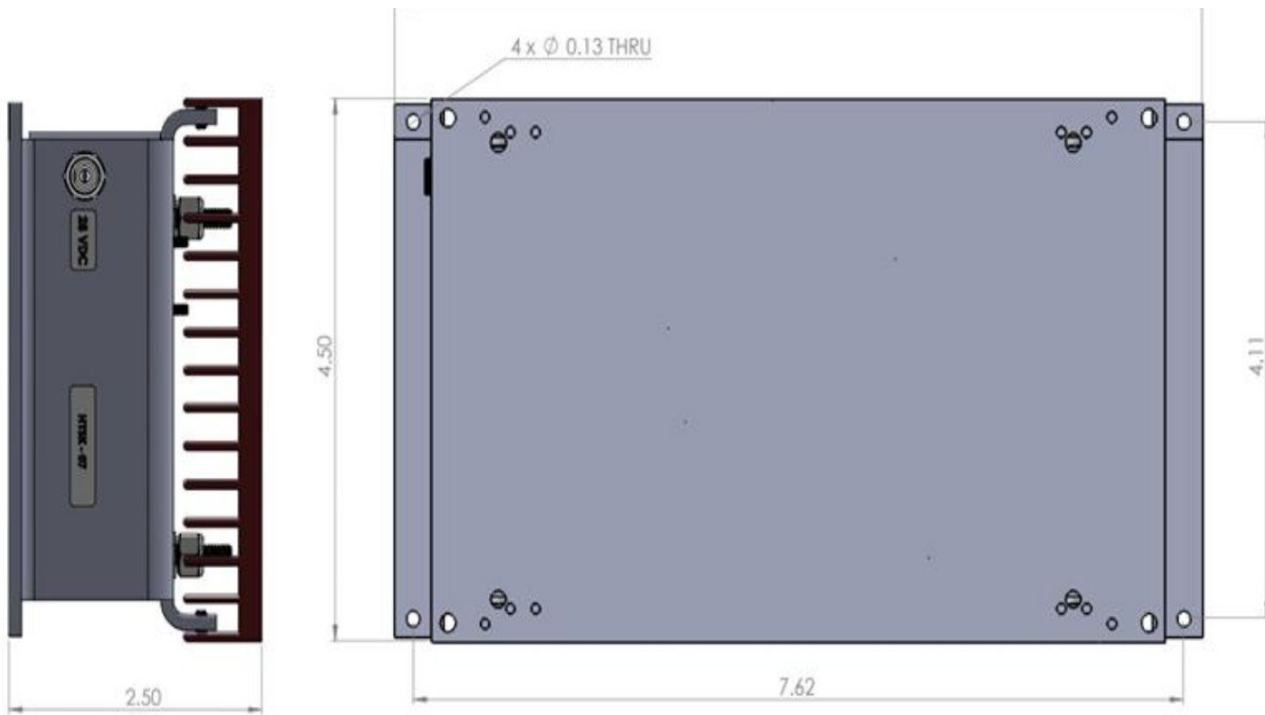

Accessory Part Numbers

Part Number	Description
PA-CBL-06-F	Standard Interface Cable Assembly - Flying Leads (included with module)
PA-CBL-06-B	Upgraded Interface Cable Assembly - Banana Plug Termination
HTSK-07	Heatsink

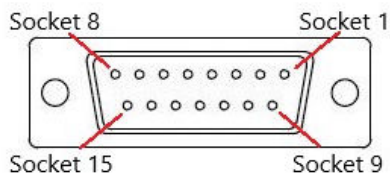

Pinout

Pin No.	Pin Name	I/O	Description	Logic Voltage
1, 2, 3, 4	V Supply	I	Primary Power (+28 VDC)	
5, 6, 7, 8	Ground	I	DC Return	
9	Temp Flag.	O	Over-temp/Fault Indicator (CMOS)	0V to +1.5V = LOW 3.5V to +5V = HIGH
10, 11, 12 13, 15	N.C.	-	N/A	
14 ¹	RF Enable	I	Transmit Control (CMOS)	0V to +1.5V = LOW 3.5V to +5V = HIGH

¹This line is internally pulled high and does not require applying voltage to this line

Contact NuWaves



NuWaves RF Solutions
132 Edison Drive
Middletown, OH 45044

www.nuwaves.com
sales@nuwaves.com
513.360.0800



For information on product disposal (end-of-life), please refer to this document:
<https://nuwaves.com/wp-content/uploads/Product-Disposal-End-of-Life.pdf>