

**USER MANUAL**  
**NUPOWER XTENDER C15RX01-C044**  
**C-BAND BIDIRECTIONAL AMPLIFIER**

**PART NUMBER:**  
**NW-BA-C-15-RX01-C044**



NuWaves RF Solutions  
132 Edison Drive  
Middletown, Ohio 45044  
PH: 513-360-0800  
FAX: 513-539-8782  
[www.nuwaves.com](http://www.nuwaves.com)  
[sales@nuwaves.com](mailto:sales@nuwaves.com)

---

---

# 1 NUPOWER XTENDER™ PRODUCT LINE OVERVIEW

---

The NuPower Xtender family of solid-state bidirectional RF amplifier modules, or “T/R modules,” is designed to meet the demanding needs of the Aerospace & Defense, Industrial, and Commercial markets. Based on the latest Gallium Nitride (GaN) technology, NuPower Xtender’s power efficiency and miniature form factor make it ideal for size, weight, and power-constrained broadband RF telemetry and tactical communications systems.

## 1.1 NUPOWER XTENDER™ PRODUCT LINE HIGHLIGHTS

---

- High Performance: Unique combination of broadband coverage, miniature form factors, and high efficiency.
- Enclosures: The NuPower Xtender family of bidirectional amplifiers is housed in a nickel-plated aluminum enclosure with mounting holes incorporated into the chassis.
- Completely Characterized: The NuPower Xtender family of solid state bidirectional amplifiers has been completely characterized over temperature, voltage, and frequency. These high-performance modules offer significant value for the OEM user or the Systems Integrator.
- User Friendly: Reverse-voltage and over-voltage protection and regulator thermal shutdown provide defenses against user interface issues.
- High Reliability: NuWaves’ selection of conservatively rated components provides high reliability. Each NuPower Xtender is inspected to IPC-A-610 Class II quality standards. NuWaves’ Quality Management System is AS9100:2016 Rev D and ISO 9001:2015 certified.
- Applications: Unmanned Aircraft Systems (UAS) • Unmanned Ground Vehicles (UGV) • Unmanned Surface Vehicles (USV) • Broadband RF Telemetry • RF Communication Systems • Software Defined Radios • Test Labs
- Available Options:
  - Fan-cooled heat sink with North American AC/DC wall plug adapter
  - Labeled interface cable with banana jack plugs

## 2 NUPOWER XTENDER C15RX01-C044 BDA OVERVIEW

The NuPower™ Xtender C15RX01-C044 BDA is a small, lightweight, and power-efficient bidirectional amplifier (BDA) ideal for extending the communication range of half-duplex C-band transceivers running constant-envelope or near-constant-envelope waveforms. The bidirectional amplifier generates at least 15 watts of RF transmit power (20 watts typical) from 5030 to 5090 MHz in transmit mode and the integrated low-noise amplifier provides a minimum of 8 dB of gain in receive mode (min).

Based on the latest gallium nitride (GaN) technology, NuPower L-Band power efficiency and < 16 in<sup>3</sup> cubic inch form factor make it ideal for size, weight, and power-constrained broadband RF telemetry and tactical communication systems.

The NuPower™ Xtender C15RX01-C044 BDA ruggedized chassis allows the system integrator to easily incorporate the unit into a platform operating in harsh environments with limited space, such as small Unmanned Aircraft Systems (UAS).

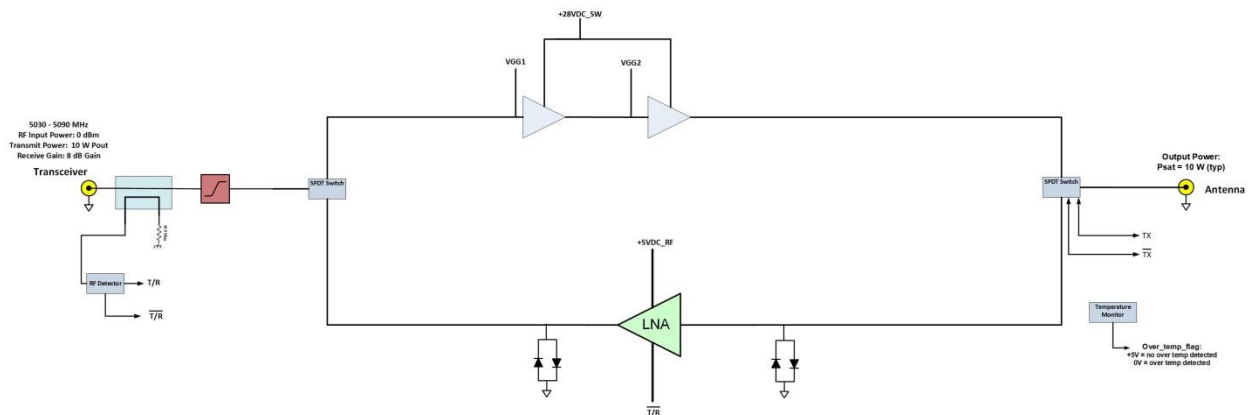

Figure 1: NuPower Xtender C15RX01-C044 Functional Diagram

## 2.1 NUPOWER XTENDER C15RX01-C044 PA SPECIFICATIONS

The subsequent tables in this section outline the NuPower Xtender C15RX01-C044 performance specifications.

**Table 1: NuPower Xtender C15RX01-C044 Electrical Specifications**

Parameter	Specification
Frequency Range	5030 to 5090 MHz
RF Output Power	15 Watts (min), 20 Watts (typ)
Transmit RF Gain	43 dB (typ)
Nominal Input Drive Level	+0 dBm
Maximum Input Drive Level	+10 dBm
Receive RF Gain	8 dB (min)
Receive Noise Figure	3.5 dB (typ)
T/R Mode	Automatic Sensing or Manual T/R Line
T/R Switch Time	1.5 $\mu$ S (max)
Supply Voltage	+11 to +32 VDC
Transmit Current Consumption	4 A @ +28 VDC (typ) 6 A @ +28 VDC (max)
Receive Current Consumption	100 mA @ +28 VDC (typ)

**Table 2: NuPower Xtender C15RX01-C044 Environmental Specifications**

Operating Conditions	Specification
Operating Temperature (100% transmit duty cycle)	-30 to +60 °C (baseplate)
Storage Temperature	-40 to +85 °C

## 2.2 NUPOWER XTENDER C15RX01-C044 PA MECHANICAL SPECIFICATIONS

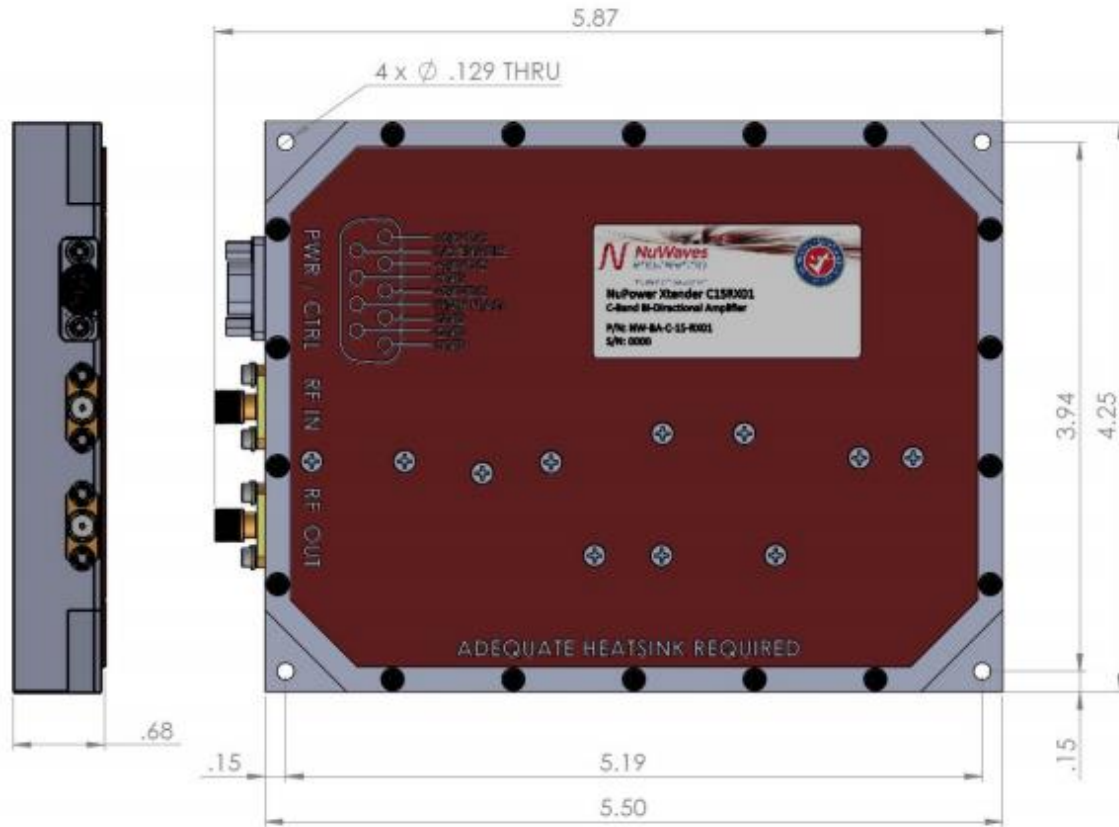

Figure 2: NuPower Xtender C15RX01-C044 Mechanical Outline

Table 3: NuPower Xtender C15RX01-C044 Mechanical Specifications

Parameter	Specification
RF Connectors	SMA (female)
Control / Power Interface Connector	9 Pin Micro-D (socket)
Dimensions (L x W x H)	5.50" x 4.25" x 0.68"
Weight	10.5 oz.

## 2.3 HEAT SINKING

The NuPower Xtender C15RX01-C044 is offered as a stand-alone module or with an accessory kit (P/N: NW-BA-ACC-KT03), which includes a 28 VDC fan-cooled heatsink and requisite power cable. [The kit also includes an upgraded module interface cable assembly, labeled and terminated with banana plugs.]

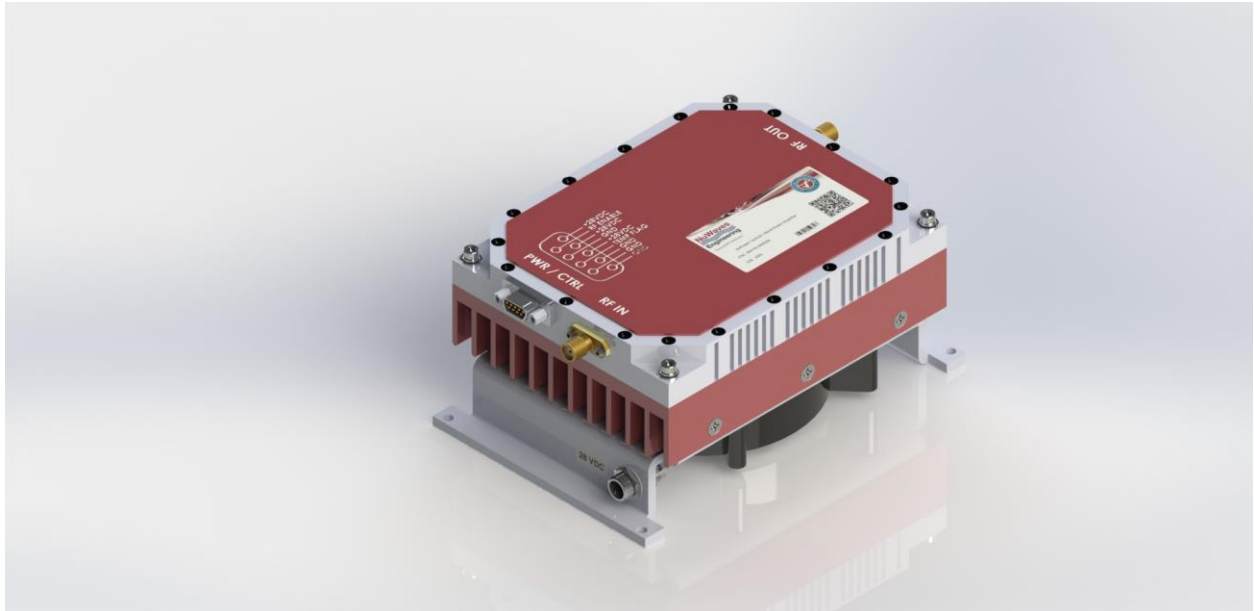

**Figure 3: The NuPower PA Kit offers “out-of-the-box” operation for the user. The 12 VDC fan-cooled heatsink is shown with the NuPower Xtender C15RX01-C044 mounted.**



Caution: The use of external heat-sinking is required especially for those applications requiring high duty cycle operation (e.g. continuous wave) or for extended on-time testing. Operation without a proper heat sink under these conditions will cause permanent damage to the product and will void the product warranty.

The max operating temperature is 85° C (baseplate).

---

## 3 SETUP AND OPERATION

---

This section provides specific details for proper operation of the NuPower Xtender C15RX01-C044 module. Following these guidelines will prevent damage to the power amplifier or external equipment.

### 3.1 POWER SUPPLY REQUIREMENTS

---

To operate the NuPower Xtender C15RX01-C044, ensure that the power supply has adequate overhead to source the current demand of the RF power amplifier. The power supply source must provide a typical voltage of +28 VDC with greater than 6 amps capability.

### 3.2 CONNECTING A PROPER LOAD TO THE ANTENNA TERMINAL

---

To prevent damage to the PA, the antenna terminal must be terminated into a 50  $\Omega$  load. Examples of a proper load include:

- Directly connecting to an antenna specified for the frequency range (5030 to 5090 MHz). Connecting to an inappropriate antenna may result in damage to the PA module.
- Connecting to a proper antenna through a 50  $\Omega$  transmission line or coaxial cable. Avoid using damaged cables or corroded connectors while attaching the unit to an antenna.
- Terminating the antenna terminal into a 50  $\Omega$  power attenuator with minimum 20 dB attenuation.
- Connecting to a load capable of dissipating the RF power from the PA module. Loads capable of handling 50 Watts (min) are recommended.

### 3.3 POWERING-UP THE NUPOWER XTENDER C15RX01-C044

---

The NuPower Xtender C15RX01-C044 must be terminated to a proper load before power is applied. Refer to Section 3.2 for the specifications of the proper load. After the PA is properly terminated, the interface cable can be connected to the unit and power can be applied. The PA is now ready for operation.

### 3.4 TRANSMIT TURN-ON TIME

---



Caution: Do not apply transmit data until the PA module is at full power. This will prevent loss of data at the beginning of a message.

The NuPower Xtender C15RX01-C044 is at full power approximately 1  $\mu$ S after the RF Enable line goes low (ground). Therefore, transmit data can be applied to the input after 1  $\mu$ S without loss of data.

### 3.5 RF OUTPUT POWER VS. SUPPLY VOLTAGE

---

The NuPower Xtender C15RX01-C044 was designed for +28 VDC operation.

## 4 HARDWARE INTERFACE

- The RF Input connector is SMA (female).
- The RF Output connector is SMA (female).
- The pin-out definitions for the 9 pin Micro-D socket connector are provided in **Error! Reference source not found.**. In a typical installation, the PA module is mated to a host controller board via a cable harness.



The RF Out SMA connector is the antenna connection. This connection should always be loaded into 50  $\Omega$ , otherwise the PA could be damaged.

### 4.1 INTERFACE CONNECTOR

The NuPower Xtender features a 9 pin Micro-D interface connector for control, power, and ground connections.

**Table 4: NuPower Xtender Interface Pin-Out Definitions**

Socket No.	Name	I/O	Description
1, 2, 6, 8	GND	I	Signal and Power Ground
3, 4, 5	V Supply	I	Primary Power (+27 to +30 VDC)
7	Temp Flag	I	Over Temperature Flag
9	T/R Enable	I/O	Transmit/Receive (T/R) Source or Sink

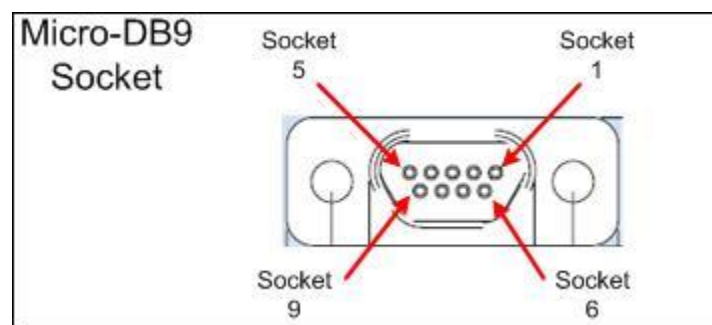

**Figure 4: Micro-D Socket Locations**

The standard interface cable harness is comprised of 9 wires, includes a Micro-D connector with pins, and mates directly to the NuPower Xtender interface connector.



---

## 4.2 DC POWER

---

The nominal supply voltage for the NuPower Xtender C15RX01-C044 is +28 VDC; The acceptable supply voltage range is +27 to +30 VDC.

---

## 4.3 GROUND

---

The signal and power grounds are tied together in the PA module.

---

## 4.4 T/R ENABLE

---

The Xtender transmit and receive switching is a manual control function. Applying a logic *low* (0 V or GND) to the T/R line places the C15RX01-C044 in transmit mode. Leaving the T/R line floating (NC), places the C15RX01-C044 in receive mode.

---

## 4.5 TEMP FLAG

---

This signal is an output to indicate an over-temperature condition in the NuPower Xtender C15RX01-C044. A logic high (+5 VDC) indicates normal operation, while a logic low (0 VDC) indicates an over-temperature condition. The NuPower Xtender C15RX01-C044 incorporates internal logic circuitry that turns off the DC bias to the RF transistors.



Caution: The amplifier should be shut down and allowed to cool off when the over-temperature flag is set low to avoid damage to the module.

---

## 5 PRODUCT DISPOSAL – END-OF-LIFE

---

Safety is a guiding principle of NuWaves RF Solutions. We ensure safe production and operation of our products, as well as end-of-life disposal. Improper disposal can adversely affect the environment, wildlife and human health. Please follow these guidelines when disposing of a NuWaves product:

- Do not remove the cover or any hardware
- Do not remove components from the circuit card assembly
- Do not incinerate
- Do not crush or shred
- Do not dispose of as unsorted municipal waste
- Do not export e-waste outside of the original destination country for recycling
- Utilize an e-Steward or ISO14001 certified e-waste recycler
- Consider export controls during recycler selection
- If a NuWaves product is incorporated into a larger system or sub-system, ensure that these guidelines are followed at system end-of-life

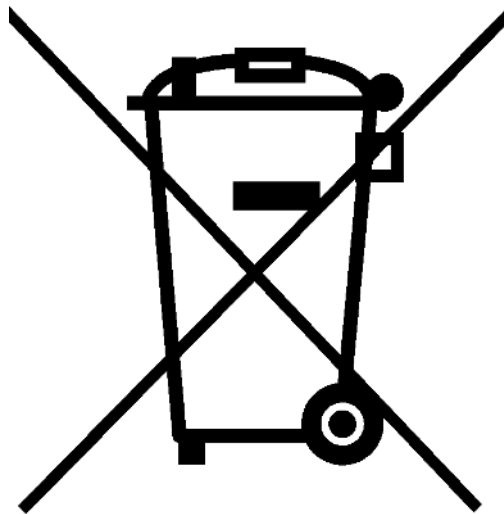

---

## 6 GETTING HELP - APPLICATIONS ENGINEERING

---

NuWaves RF Solutions offers technical support for basic configuration help and troubleshooting, Monday through Friday, 8 a.m. to 5 p.m. Eastern Time.

Technical Assistance, Application Engineering and Sales:

Phone: (513) 360-0800

Email: [support@nuwaves.com](mailto:support@nuwaves.com)

NuWaves Home Page: <https://www.nuwaves.com/>

Product Warranty:

[https://nuwaves.com/wp-content/uploads/NuWaves\\_Warranty\\_Repair.pdf](https://nuwaves.com/wp-content/uploads/NuWaves_Warranty_Repair.pdf)

### 6.1 GENERAL INFORMATION

---

Copyright © 2006 – 2019 NuWaves Ltd. All rights reserved. The information contained in this user manual is copyright protected. NuWaves reserves the right to make periodic modifications and product improvements to the NuPower product line and the associated documentation.