

USER MANUAL

NUPOWER XTENDER C10RX03

BIDIRECTIONAL C-BAND AMPLIFIER

PART NUMBER:
NW-BA-C-10-RX03



NuWaves RF Solutions
132 Edison Drive
Middletown, Ohio 45044
PH: 513-360-0800
FAX: 513-539-8782
www.nuwaves.com
sales@nuwaves.com

1 NUPOWER XTENDER™ PRODUCT LINE OVERVIEW

The NuPower Xtender family of solid state bidirectional RF amplifier modules, or “T/R modules,” is designed to meet the demanding needs of the Aerospace & Defense, Industrial, and Commercial markets. Based on the latest Gallium Nitride (GaN) technology, NuPower Xtender’s power efficiency and miniature form factor make it ideal for size, weight, and power-constrained broadband RF telemetry and tactical communications systems.

1.1 NUPOWER XTENDER™ PRODUCT LINE HIGHLIGHTS

- High Performance: Unique combination of broadband coverage, miniature form factors, and high efficiency.
- Enclosures: The NuPower Xtender family of bidirectional amplifiers is housed in an aluminum enclosure with mounting holes incorporated into the chassis.
- Completely Characterized: The NuPower Xtender family of solid state bidirectional amplifiers has been completely characterized over temperature, voltage, and frequency. These high-performance modules offer significant value for the OEM user or the Systems Integrator.
- User Friendly: Over-voltage protection and regulator thermal shutdown provide defenses against user interface issues.
- High Reliability: NuWaves’ selection of conservatively rated components provides high reliability. Each NuPower is inspected to IPC-A-610 Class II quality standards. NuWaves’ Quality Management System is AS9100:2016 Rev D and ISO 9001:2015 certified.
- Applications: Unmanned Aircraft Systems (UAS) • Unmanned Ground Vehicles (UGV) • Unmanned Surface Vehicles (USV) • Broadband RF Telemetry • RF Communication Systems • Software Defined Radios • Test Labs
- Available Options:
 - Fan-cooled heat sink with North American AC/DC wall plug adapter
 - Labeled interface cable with banana jack plugs

2 NUPOWER XTENDER C10RX03 OVERVIEW

The NuPower Xtender™ C10RX03 Bidirectional C-Band Amplifier module is a small, lightweight, and power-efficient bidirectional amplifier (BDA) ideal for extending the communication range of half-duplex transceivers using continuous wave (CW) and near-constant envelope waveforms. The bidirectional amplifier generates 10 watts (P_{sat}) from 4400 to 5100 MHz in transmit mode and the integrated low-noise amplifier provides 10 dB of gain in receive mode.

Based on the latest Gallium Nitride (GaN) technology, NuPower’s high-efficiency and 4.6 in.³ form factor make it ideal for SWaP-constrained applications. In addition, NuPower’s broadband frequency coverage supports operational flexibility.

NuPower Xtender bidirectional amplifiers are designed with a ruggedized chassis for high-reliability in harsh environments.

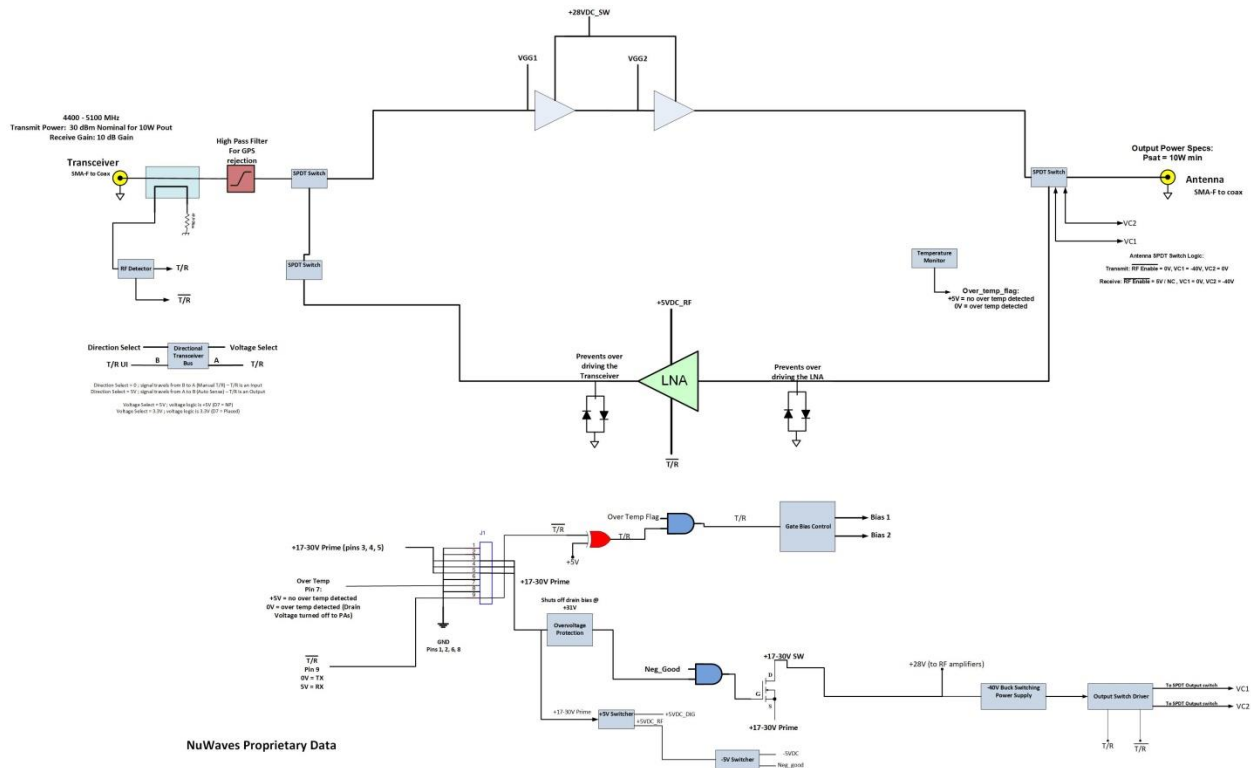

Figure 1: NuPower Xtender C10RX03 Functional Diagram

2.1 PRELIMINARY SPECIFICATIONS

The subsequent tables in this section outline the NuPower Xtender C10RX03's performance specifications.

Table 1: NuPower Xtender C10RX03 Electrical Specifications

Parameter	Specification
Frequency Range	4400 to 5100 MHz
RF Output Power, Psat	10 Watts (typ)
Transmit RF Gain	10 dB (typ)
Nominal Input Drive Level	+30 dBm
Maximum Input Drive Level	+33 dBm
Receive RF Gain	10 dB (typ)
Receive Noise Figure	3.0 dB (typ)
T/R Mode	Automatic Sensing
T/R Switch Time	2 μ S
Supply Voltage	28 VDC
Transmit Current Consumption	1.75 A @ +28 VDC (typ) @ Pout = 10 W
Receive Current Consumption	45 mA @ +28 VDC (typ)

Table 2: NuPower Xtender C10RX03 Environmental Specifications

Operating Conditions	Specification
Operating Temperature (100% transmit duty cycle)	-40 to +85 °C (baseplate)
Storage Temperature	-60 to +100 °C

2.1.1 MECHANICAL SPECIFICATIONS

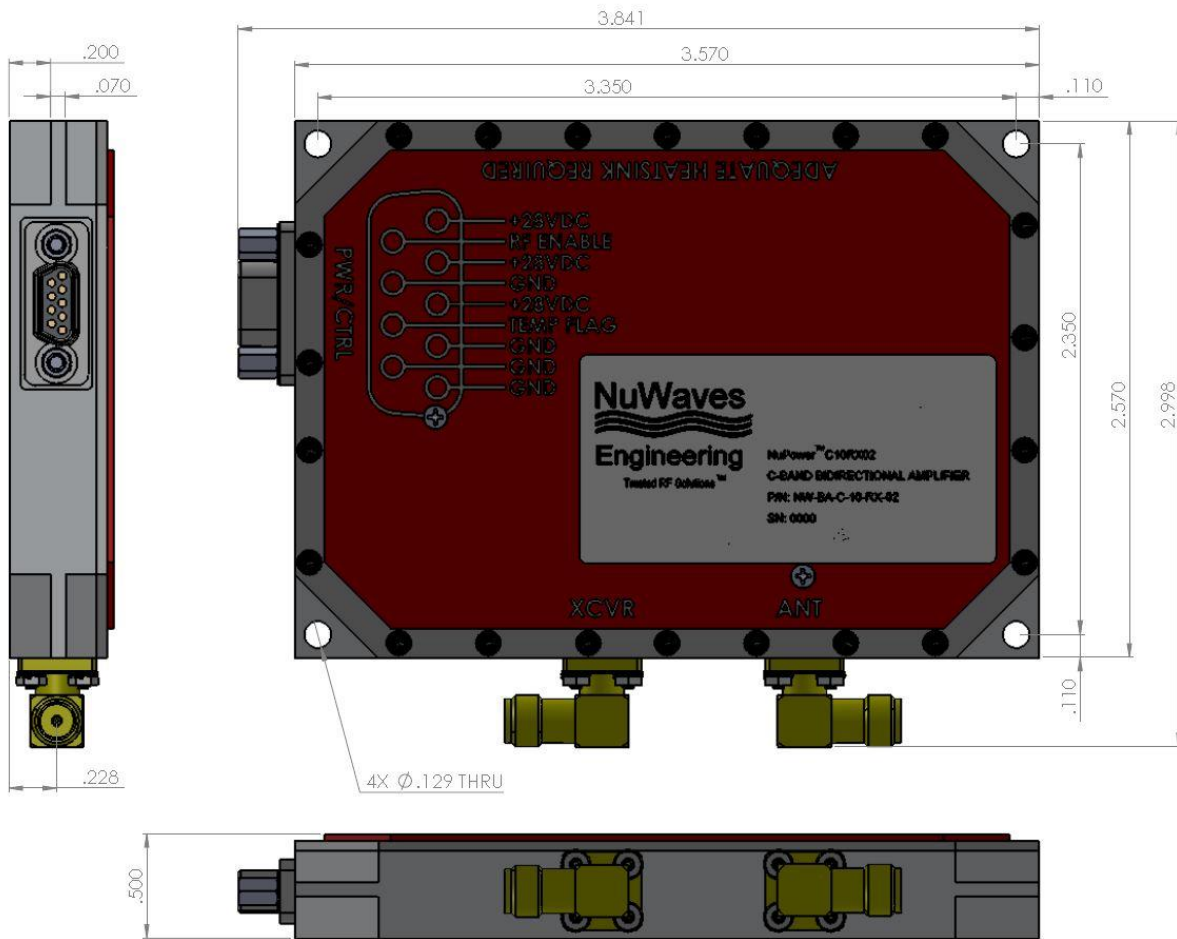

Figure 2: NuPower Xtender C10RX03 Mechanical Outline

Table 3: NuPower Xtender C10RX03 Mechanical Specifications

Parameter	Specification
RF Connectors	SMA (female), right angle
Control / Power Interface Connector	9 Pin Micro-D (socket)
Dimensions (L x W x H)	3.57" x 2.57" x 0.5"
Weight	5.0 oz.

2.2 HEAT SINKING

The NuPower Xtender C10RX03 is offered as a stand-alone module, or as part of a kit, which also includes a fan-cooled heat sink with an AC/DC adapter and an interface cable with banana jack plug terminations. The fan-cooled heat sink provides sufficient cooling for operating the NuPower Xtender at room temperature (25 °C), however higher ambient temperatures may require additional heat-sinking to maintain a baseplate temperature below 60 °C at 100% transmit duty cycle.



Figure 3: The NuPower PA Kit offers “out-of-the-box” operation for the user. The fan-cooled heatsink is shown with an example PA (NuPower Xtender not shown).



Caution: The use of external heat-sinking is required especially for those applications requiring high duty cycle operation (e.g. continuous wave) or for extended on-time testing. Operation without a proper heat sink under these conditions will cause permanent damage to the product and will void the product warranty.

3 SETUP AND OPERATION

This section provides specific details for proper operation of the NuPower Xtender module. Following these guidelines will prevent damage to the bidirectional amplifier or external equipment.

3.1 POWER SUPPLY REQUIREMENTS

To operate the NuPower Xtender C10RX03, ensure that the power supply has adequate overhead to source the current demand of the RF amplifier. The power supply source must provide a voltage of +28 VDC with greater than 5 amps capability.

3.2 CONNECTING A PROPER LOAD TO THE ANTENNA TERMINAL

To prevent damage to the amplifier module, the antenna terminal must be terminated into a 50 Ω load. Examples of a proper load include:

- Directly connecting to an antenna specified for the frequency range (4400 to 5100 MHz). Connecting to an inappropriate antenna may result in damage to the amplifier module.
- Connecting to a proper antenna through a 50 Ω transmission line or coaxial cable. Avoid using damaged cables or corroded connectors while attaching the unit to an antenna.
- Terminating the antenna terminal into a 50 Ω power attenuator with minimum 20 dB attenuation.
- Connecting to a 50 Ω load capable of dissipating the RF power from the amplifier module. Loads capable of handling 30 Watts (min) are recommended.

3.3 POWERING-UP THE NUPOWER XTENDER

The NuPower Xtender C10RX03 must be terminated into a proper load before power is applied. Refer to Section 3.2 for the specifications of the proper load. After the amplifier is properly terminated, the interface cable can be connected to the unit and power can be applied. The amplifier is now ready for operation.

4 HARDWARE INTERFACE

- The transceiver interface connector, “XCVR,” is SMA (female).
- The antenna connector, “ANT,” is SMA (female).
- The pin-out definitions for the 9 pin Micro-D socket connector, “CTRL/PWR,” are provided in Table 4. In a typical installation, the amplifier module is mated to a host controller board via a cable harness.



The ANT SMA connector is the antenna connection. This connection should always be loaded into 50 Ω , otherwise the amplifier could be damaged.

4.1 INTERFACE CONNECTOR

The NuPower Xtender C10RX03 features a 9 pin Micro-D interface connector for control, power, and ground connections.

Table 4: NuPower Xtender Interface Pin-Out Definitions

Socket No.	Name	I/O	Description
3, 4, 5	V Supply	I	Primary Power (+28 VDC)
1, 2, 6, 8	GND	I	Signal and Power Ground
7	Temp	O	Over Temperature Flag
9	TR_EN	O	Transmit / Receive Control

The standard interface cable harness is comprised of 9 wires, includes a Micro-D connector with pins, and mates directly to the NuPower Xtender interface connector.

4.2 DC POWER

The nominal supply voltage for the NuPower Xtender C10RX03 is +28 VDC.

4.3 GROUND

The signal and power grounds are tied together in the amplifier module.

4.4 OVER TEMPERATURE FLAG

This signal is an output to indicate an over-temperature condition in the NuPower Xtender C10RX03. A logic high (+3.3 VDC or +5 VDC, factory set) indicates normal operation, while a logic low (0 VDC) indicates an over-temperature condition. The Xtender C10RX03 incorporates internal logic circuitry that turns off the DC bias to the RF transistors. This unit also incorporates a temperature back off feature, where it will reduce power initially to generate less heat and reduce the risk of damage before it finally reaches the trip point.



Caution: The amplifier should be shut down and allowed to cool off when the over-temperature flag is set low to avoid damage to the module.

4.5 TRANSMIT/RECEIVE (T/R) CONTROL

The Xtender C10RX03 is configured for autosense transmit/receive (T/R) switching. The module switches to transmit with an RF input greater than ~+15 dBm, and switches to receive when the RF input is below ~0 dBm. The T/R status can be monitored on this line: logic low (0 VDC) = Transmit, logic high (+3.3 VDC or +5 VDC, factory set) = Receive.

5 PRODUCT DISPOSAL – END-OF-LIFE

Safety is a guiding principle of NuWaves RF Solutions. We ensure safe production and operation of our products, as well as end-of-life disposal. Improper disposal can adversely affect the environment, wildlife and human health. Please follow these guidelines when disposing of a NuWaves product:

- Do not remove the cover or any hardware
- Do not remove components from the circuit card assembly
- Do not incinerate
- Do not crush or shred
- Do not dispose of as unsorted municipal waste
- Do not export e-waste outside of the original destination country for recycling
- Utilize an e-Steward or ISO14001 certified e-waste recycler
- Consider export controls during recycler selection
- If a NuWaves product is incorporated into a larger system or sub-system, ensure that these guidelines are followed at system end-of-life

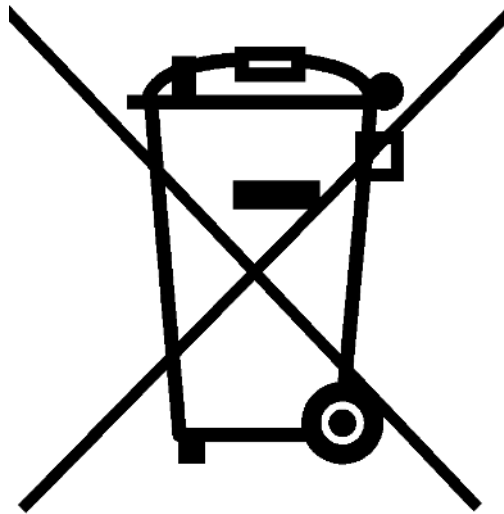

6 GETTING HELP - APPLICATIONS ENGINEERING

NuWaves RF Solutions offers technical support for basic configuration help and troubleshooting, Monday through Friday, 8 a.m. to 5 p.m. Eastern Time.

Technical Assistance, Application Engineering, and Sales:

Email: sales@nuwaves.com

Phone: (513) 360-0800

NuWaves Home Page: <https://www.nuwaves.com/>

Product Warranty:

https://nuwaves.com/wp-content/uploads/NuWaves_Warranty_Repair.pdf

6.1 GENERAL INFORMATION

Copyright © 2006 NuWaves Ltd. All rights reserved. The information contained in this user manual is copyright protected. NuWaves reserves the right to make periodic modifications and product improvements to the NuPower product line and the associated documentation.