

# USER MANUAL

## HIGH INTERCEPT LOW NOISE AMPLIFIER (HILNA™)

### MODEL: HILNA V1



NuWaves Engineering  
132 Edison Drive  
Middletown, Ohio 45044  
PH: 513-360-0800  
FAX: 513-539-8782  
[www.nuwaves.com](http://www.nuwaves.com)  
[sales@nuwaves.com](mailto:sales@nuwaves.com)

---

---

## 1 HILNA™ PRODUCT LINE OVERVIEW

---

NuWaves' HILNA family of low noise amplifiers (LNAs) is designed to achieve high RF gain while maintaining extremely low noise, and high third-order intercept point across a wide band. The HILNA's robust power supply also operates over a very broad range easily allowing the unit to be integrated into systems without regard to power supply precision.

### 1.1 HILNA™ PRODUCT LINE HIGHLIGHTS

---

- High Performance - Noise, Gain, Intercept, Dynamic Range: Unique combination of extremely low noise, high gain, high output intercept, and wide band frequency coverage.
- Robust Power Supply: Operates over a very broad range of power supply voltages. Included with each LNA is a power connector with cable.
- Enclosures:
  - The HILNA V1, HILNA G2V1, HILNA HF, and HILNA CF are housed in a black-anodized extruded aluminum enclosure with optional mounting flanges
  - The HILNA GPS is housed in a silver-anodized extruded aluminum enclosure with optional mounting flanges
  - The  $\mu$ HILNA is housed in a miniature sleek black anodized milled aluminum enclosure with mounting holes incorporated into the chassis.
  - The HILNA LS is housed in a black anodized milled aluminum enclosure with mounting holes incorporated into the chassis.
  - The HILNA CX is housed in a nickel plated rugged aluminum enclosure with mounting holes incorporated into the chassis.
- Completely Characterized: The HILNA family of low noise amplifiers has been completely characterized over temperature, voltage, and frequency. The amplifiers are robust, offering significant value for the OEM user or the Systems Integrator.
- User Friendly: Reverse-voltage protection and regulator thermal shutdown provide defenses against user interface issues.
- High Reliability: NuWaves' selection of conservatively rated components provides high reliability. Each HILNA is inspected to IPC-A-610 Class II quality standards. NuWaves' Quality Management System is AS9100:2016 Rev D and ISO 9001:2015 certified.
- ESD Protection: The HILNA Amplifiers are suitable for many types of applications where ESD susceptibility is prominent. The amplifiers are designed to withstand up to 1000 V utilizing ESD waveforms described in IEC 61000 4-2.

- Applications: IF or RF Buffer Amplifier ▪ Military Radios ▪ RF Wideband Front-Ends ▪ RF Pre-Amp ▪ TV ▪ Final Stage Amplifier for Low-Level Repeaters ▪ Ultra Low Noise Applications ▪ LNA for Cellular Base Station ▪ High Linearity Systems ▪ High-Performance Receivers ▪ High-Power Drive Signals for Increased Dynamic Range ▪ High Reliability RF Amplifier Applications ▪ Base Station Applications ▪ VHF/UHF Amplification ▪ Final PA for Low-Power Applications ▪ Low-Noise Transmit Driver ▪ Cable Modem ▪ Fixed Wireless ▪ Mobile Infrastructure ▪ Industrial/Scientific/Medical Band Applications

## 1.2 HILNA™ PRODUCT LINE MODELS

NuWaves offers several variants of the HILNA line-up. Product availability is depicted in Table 1.

**Table 1: List of Models**

MODEL	DESCRIPTION
HILNA V1	50 MHz to 1 GHz, 20 dB Gain
μHILNA	50 MHz to 1500 MHz, 20 dB Gain
HILNA G2V1	50 MHz to 1 GHz, 40 dB Gain
HILNA GPS	1.2 GHz to 1.6 GHz, 32 dB Gain
HILNA CF	50 MHz to 1 GHz, 38 dB Gain
HILNA HF	2 MHz to 50 MHz, 30 dB Gain
HILNA LS	1 GHz to 3 GHz, 50 dB Gain
HILNA CX	5 GHz to 10 GHz, 30 dB to 43 dB Gain

## 2 HILNA™ V1 OVERVIEW

NuWaves' HILNA V1 is the first in its class of broadband low noise amplifiers designed to achieve high gain while maintaining low noise and a high third order intercept point from VHF to microwave frequencies.

This high-performance module delivers 20 dB of gain across the frequency range of 50 MHz to 1000 MHz, with an OIP3 of +32 dBm and less than 1 dB of noise figure.

HILNA V1's robust power supply also operates over a very broad range easily allowing the unit to be integrated into systems without regard to power supply precision.

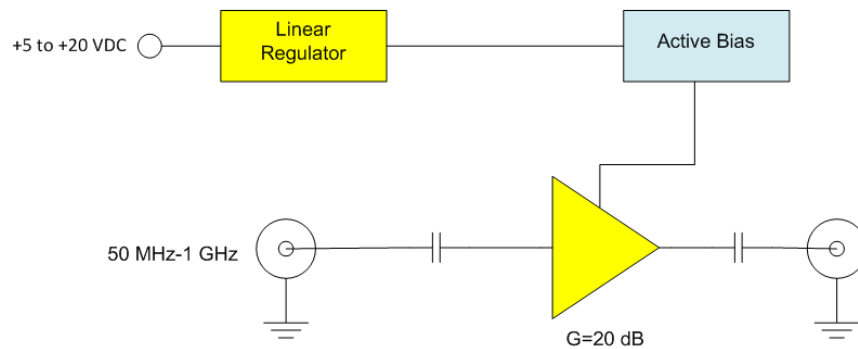

Figure 1: HILNA V1 Functional Diagram

### 2.1 HILNA V1 ELECTRICAL DATA

Table 2: HILNA V1 Maximum Operating Specifications

Operating Voltage	+20 VDC
RF Input Power	+15 dBm
Operating Temperature	-30 to +70 °C
Storage Temperature	-40 to +85 °C

**Table 3: HILNA V1 DC Specifications**

	<b>Unit</b>	<b>Min</b>	<b>Typ</b>	<b>Max</b>
Operating Voltage	V	+5		+20
Current Consumption	mA		70	

**Table 4: HILNA V1 RF Specifications**

<b>PARAMETER</b>	<b>UNIT</b>	<b>HILNA V1</b>		
		<b>Min</b>	<b>Typ</b>	<b>Max</b>
Frequency Range	MHz	50		1000
Gain	dB	17	20	
Noise Figure	dB	0.7	0.8	1.6
OIP3	dBm	28	32	
P1dB	dBm	15	17	
VSWR In			1.5:1	
VSWR Out			1.5:1	
Reverse Isolation	dB	26	27	

## 2.2 FREQUENCY RESPONSE GRAPH

Figure 2 depicts the HILNA V1’s gain across 50 to 1000 MHz.

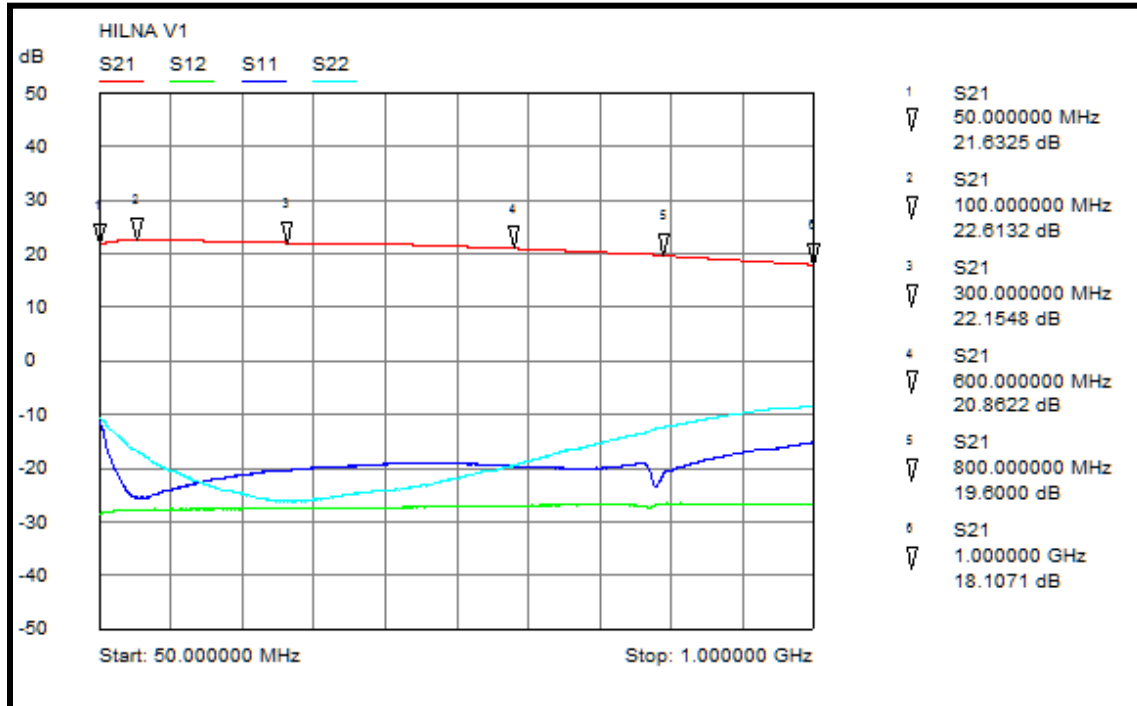

Figure 2: The HILNA V1 provides 20 dB (typ) of gain across the frequency range of 50 to 1000 MHz.

### 2.3 HILNA V1 MECHANICAL SPECIFICATIONS

The HILNA V1 is housed in a sleek black anodized extruded aluminum enclosure. Figure 3 shows the mechanical outline of the HILNA V1 with the optional mounting flanges.

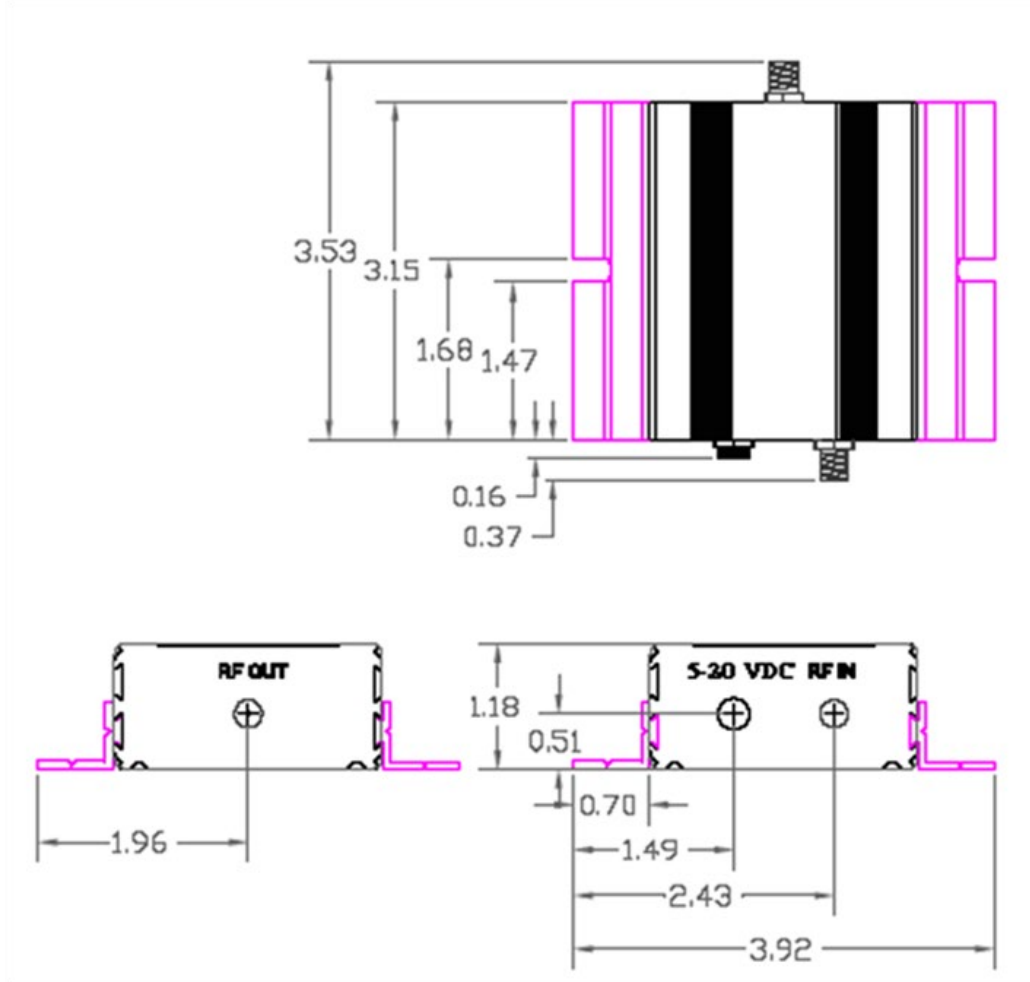

Figure 3: The HILNA V1 mechanical outline is shown with the optional mounting flanges.

Table 5: HILNA V1 Mechanical Specifications

RF Bulkhead Connectors	SMA female
DC Power Connector	2 mm Circular
Dimensions (L x W x H) without mounting flanges	3.15" x 2.52" x 1.18"
Dimensions (L x W x H) with mounting flanges	3.15" x 3.92" x 1.18"
Weight	5.7 oz.

## 3 INSTALLING, CONNECTING, AND USING THE HILNA

---

The HILNA modules have been designed to be highly reliable under the specified operating conditions. The following installation and interfacing guidelines should be followed to prevent damage to the RF module.

**Caution: The HILNA module contains components that are sensitive to Electro-Static Discharge (ESD). Wrist-straps, mats, and ground-straps should be used during the installation process.**



### 3.1 CABLING

---

The HILNA V1 is equipped with high-performance RF connectors. Gold plated SMA-type receptacles are used because they perform very well across the usable frequency range of the unit. For optimal performance, a high-quality 50  $\Omega$  coaxial cable with SMA-type plugs should be used to interface with the amplifier.

**Caution: Due to the wideband nature of the unit, installation should not be attempted on a tower with in-band transmit antennas.**

If cables with the SMA-type connectors are not available, high-quality adaptors are available for most coaxial connector types.

### 3.2 POWER SUPPLY

---

The HILNA V1 contains internal linear voltage regulators. These regulators protect the circuitry from voltage variations at the input and allow for the wide operating voltage. The power connector for the units is an industry-standard 2 mm circular connector. The only restrictions on the power source for the unit are:

- Capable of sourcing 90 mA of current.
- Capable of sourcing +5 VDC to +20 VDC

Car batteries (through a cigarette lighter adaptor), laboratory DC power supplies, or wall transformers are suitable power sources as long as the superimposed ripple is low in amplitude.



### 3.3 CONNECTIONS

---

**Caution: Do not apply RF to the unit before all cable connections are made and power has been applied.**

Making the connections from the HILNA V1 is easily accomplished:

1. Connect the "RF OUT" connector on the unit to a 50  $\Omega$  coaxial cable.
2. Plug in the power cable sent with the unit into the DC power input.
3. Connect the red lead to the positive side of the power supply and connect the black lead to the negative side of the power supply. Power is now ready to be applied to the unit.
4. Connect the RF Source to the "RF IN" port with a second 50  $\Omega$  coaxial cable.
5. Apply RF to the input cable assembly.

Powering down the unit is done by reversing this procedure.

Connection Summary:

1. Connect the RF Output to a good load. The characteristic impedance is 50  $\Omega$ .
2. Apply DC (+12 VDC Typical) at the power connector.
3. Connect an RF source to the RF Input connector.



**Caution: Excess drive levels at the input to the amplifier can permanently damage the unit. Under no circumstance should the RF input level exceed +15 dBm.**

### 3.4 ENVIRONMENTAL SPECIFICATIONS

---

The HILNA V1 units are rated for operation from -30 to +70 °C. The enclosure is **NOT** watertight so the unit must be kept dry. It is recommended that the unit be installed in a well-ventilated area or mounted to a heat sink if the input voltage exceeds +12 VDC. The unit will run warmer as the input voltage increases.

---

## 4 PRODUCT DISPOSAL – END-OF-LIFE

---

Safety is a guiding principle of NuWaves RF Solutions. We ensure safe production and operation of our products, as well as end-of-life disposal. Improper disposal can adversely affect the environment, wildlife and human health. Please follow these guidelines when disposing of a NuWaves product:

- Do not remove the cover or any hardware
- Do not remove components from the circuit card assembly
- Do not incinerate
- Do not crush or shred
- Do not dispose of as unsorted municipal waste
- Do not export e-waste outside of the original destination country for recycling
- Utilize an e-Steward or ISO14001 certified e-waste recycler
- Consider export controls during recycler selection
- If a NuWaves product is incorporated into a larger system or sub-system, ensure that these guidelines are followed at system end-of-life

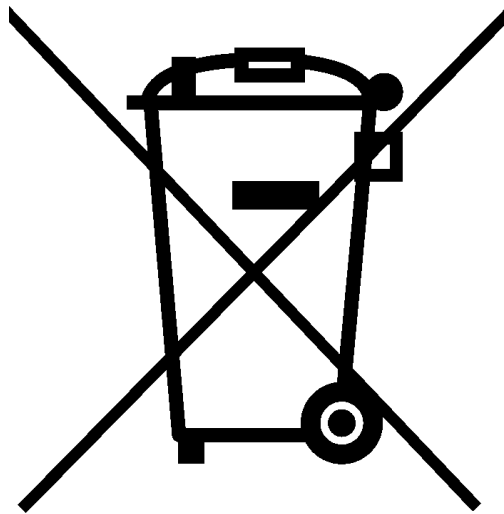

---

## 5 GETTING HELP - APPLICATIONS ENGINEERING

---

NuWaves RF Solutions offers technical support for basic configuration help and troubleshooting, Monday through Friday, 8 a.m. to 5 p.m. Eastern Time.

Technical Assistance, Application Engineering and Sales:

Phone: (513) 360-0800

Email: [sales@nuwaves.com](mailto:sales@nuwaves.com)

NuWaves Home Page: <https://www.nuwaves.com/>

Product Warranty:

[https://products.nuwaves.com/wp-content/uploads/NuWaves\\_Warranty\\_Repair.pdf](https://products.nuwaves.com/wp-content/uploads/NuWaves_Warranty_Repair.pdf)

### 5.1 GENERAL INFORMATION

---

Copyright © 2006 – 2019 NuWaves Ltd. All rights reserved. The information contained in this user manual is copyright protected. NuWaves reserves the right to make periodic modifications and product improvements to the HILNA product line and the associated documentation.