

USER MANUAL

HIGH INTERCEPT LOW NOISE AMPLIFIER (HILNA™)

MODEL: HILNA LS-C021



NuWaves Engineering
132 Edison Drive
Middletown, Ohio 45044
PH: 513-360-0800
www.nuwaves.com
sales@nuwaves.com

1 HILNA™ PRODUCT LINE OVERVIEW

NuWaves' HILNA family of amplifiers is designed to achieve high RF gain while maintaining extremely low noise, and high third-order intercept point across a wide band. HILNA's robust power supply also operates over a very broad range easily allowing the unit to be integrated into systems without regard to power supply precision.

1.1 HILNA™ PRODUCT LINE HIGHLIGHTS

- High Performance - Noise, Gain, Intercept, Dynamic Range: Unique combination of extremely low noise, high gain, high output intercept, and wide band frequency coverage.
- Robust Power Supply: Operates over a very broad range of power supply voltages. Included with each amplifier is a mating power connector with cable attached.
- Enclosures:
 - HILNA V1, HILNA G2V1, HILNA GPS, HILNA HF, and HILNA CF are housed in a black or silver anodized extruded aluminum enclosure with mounting flanges.
 - μ HILNA is housed in a miniature sleek black anodized milled aluminum enclosure.
 - HILNA LS is housed in a black anodized milled aluminum enclosure with mounting holes incorporated into the chassis
 - HILNA CX is housed in a nickel plated rugged aluminum enclosure with mounting holes incorporated into the chassis.
- Completely Characterized: The HILNA family of low noise amplifiers has been completely characterized over temperature, voltage, and frequency. The amplifiers are robust, offering significant value for the OEM user or the Systems Integrator.
- User Friendly: Reverse-voltage protection and regulator thermal shutdown provide defenses against user interface issues.
- High Reliability: NuWaves' selection of conservatively rated components provides high reliability delivering high Mean Time Between Failure (MTBF) numbers. Each HILNA is inspected to IPC-A-610 Class III quality standards. NuWaves' Quality Management System is AS9100:2016 Rev D and ISO 9001:2015 certified.
- ESD Protection: The HILNA Amplifiers are suitable for many types of applications where ESD susceptibility is prominent. The amplifiers are designed to withstand up to 1000 V utilizing ESD waveforms described in IEC 61000 4-2.

- Applications: IF or RF Buffer Amplifier ▪ Overcome Systematic RF Losses ▪ Increase Antenna Signal Levels ▪ Military Radios ▪ RF Wideband Front-Ends ▪ RF Pre-Amp ▪ TV ▪ Final Stage Amplifier for Low-Level Repeaters ▪ Long Cable Runs to Antenna ▪ Ultra Low Noise Applications ▪ LNA for Cellular Base Station ▪ High Linearity Systems ▪ General Purpose Amplification ▪ High Performance Receivers ▪ High Power Drive Signals for Increased Dynamic Range ▪ High Reliability RF Amplifier Applications ▪ Base Station Applications ▪ VHF/UHF Amplification ▪ Final PA for Low-Power Applications ▪ Low-Noise Transmit Driver ▪ Cable Modem ▪ Fixed Wireless ▪ Mobile Infrastructure ▪ Industrial Scientific Medical Band Applications
- Users: Engineering and Scientific Laboratories ▪ Test and Measurement Facilities ▪ OEMs of RF High End Systems ▪ Research Laboratories ▪ Communications Engineering Firms ▪ Cable TV System Engineers ▪ RF System Integrators ▪ Test Ranges ▪ Universities ▪ Antenna Design Facilities ▪ Field Service Technicians ▪ Aerospace and Defense Systems ▪ Radio and TV Engineers ▪ Amateur Radio ▪ Scientific and Consulting Agencies ▪ Radio and Wireless Communication Services ▪ Precision Equipment Repair Organizations ▪ Professional and Technical Service Institutions ▪ Military Radio & Communication Facilities product models

2 HILNA™ LS-C021 OVERVIEW

NuWaves' HILNA™ LS-C021 is a broadband low noise amplifier covering L- & S-bands, and designed to achieve extremely high gain while maintaining low noise and a high third-order intercept point.

This high-performance module delivers 15 dB of gain over the broad range of 1.65 GHz to 2.5 GHz with a noise figure of less than 2.5 dB and OIP3 of +33 dBm. The HILNA-LS-C021 is also useable from 500 MHz to 3.75 GHz with 12 dB of gain. The HILNA-LS-C021 has a small form factor (3.3 in³) making it ideal for small communication system installations, co-located to the antenna. In addition, the HILNA-LS-C021 has a built-in bias-T capability eliminating the need for a separate power cable run.

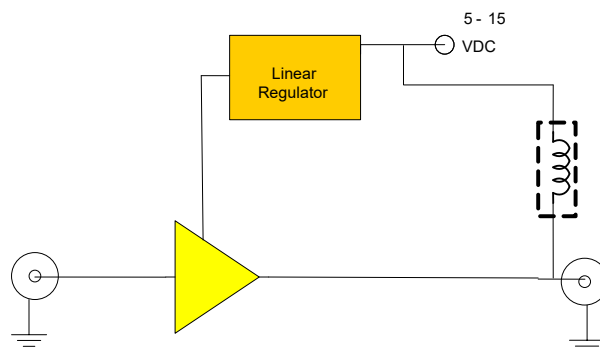

Figure 1: HILNA LS-C021 Functional Diagram

2.1 HILNA LS-C021 ELECTRICAL DATA

Table 1: HILNA LS-C021 Absolute Maximum Rating

Operating Voltage	+15 VDC
RF P _{in}	+20 dBm
Operating Temperature	-20 to + 60 °C
Storage Temperature	-40 to + 85 °C

Table 2: HILNA LS-C021 Power Specifications

		Min	Typ	Max
Operating Voltage	VDC	+5	+12	+15
Current Consumption	mA		130	

Table 3: HILNA LS-C021 RF Specifications

PARAMETER	UNIT	HILNA LS		
		Min	Typ	Max
Frequency Range	GHz	1.65		2.5
Gain	dB		15	
Noise Figure	dB		1.8	
OIP3	dBm		+33	
P1dB	dBm		+18	
VSWR In			1.8:1	
VSWR Out			1.8:1	
Reverse Isolation	dB		38	

2.2 FREQUENCY RESPONSE GRAPH

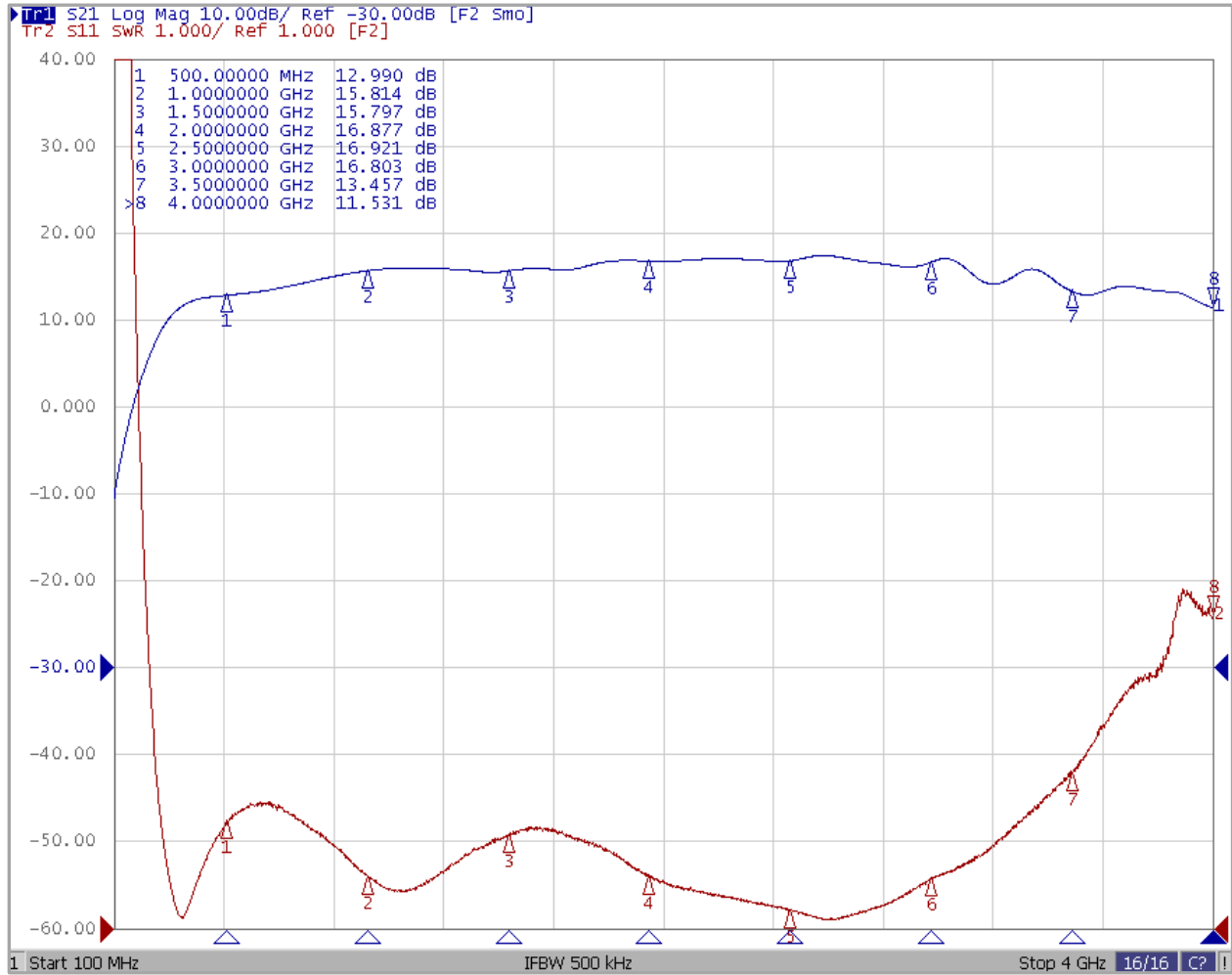

Figure 2: HILNA LS-C021 Frequency Response

2.3 HILNA LS-C021 MECHANICAL SPECIFICATIONS

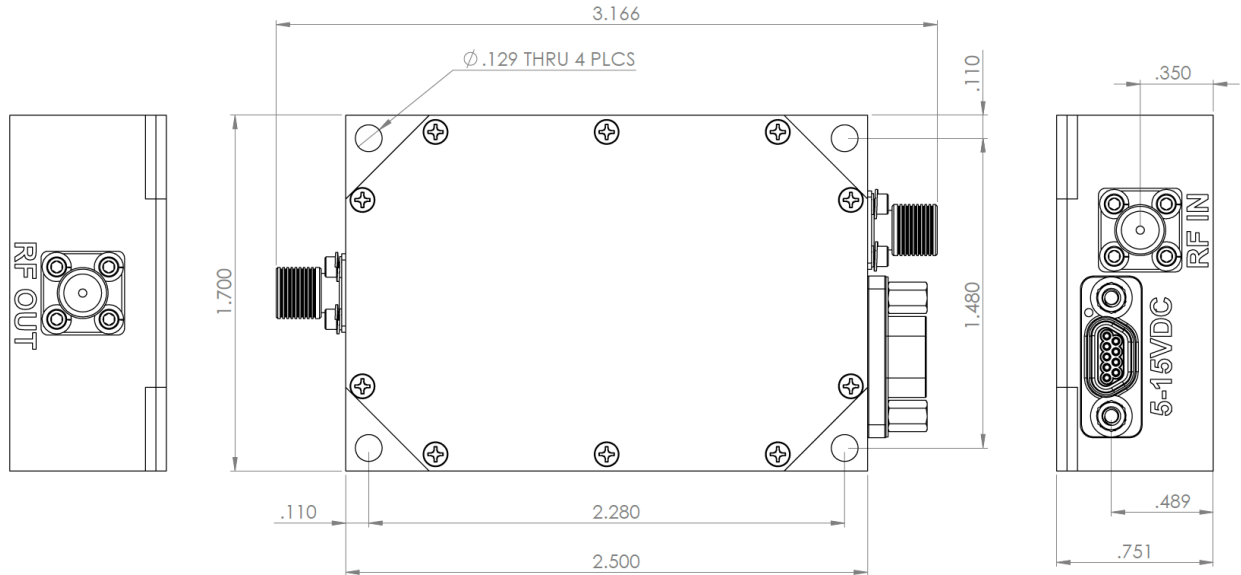

Figure 3: HILNA LS Mechanical Outline

Table 4: HILNA LS Mechanical Specifications

RF Bulkhead Connector	SMA female
RF Input and Output Mating Connector	SMA male
DC Power Connector	4-pin Mini USB
Dimensions (L x W x H)	2.50" x 1.75" x 0.75"
Weight	3.00 oz.

3 INSTALLING, CONNECTING, AND USING THE HILNA AMPLIFIER

HILNA amplifiers have been designed to be highly reliable under the specified operating conditions. The following installation and interfacing guidelines should be followed to prevent damage to the RF module.

Caution: The HILNA amplifier contains components that are sensitive to Electro-Static Discharge (ESD). The use of wrist strap, mats, and ground straps should be adhered to during the installation process.



3.1 CABLING

The HILNA LS-C021 is equipped with high-performance RF connectors. Gold plated SMA-type receptacles are used because they perform very well across the usable frequency range of the unit. For optimal performance, a high-quality 50 Ω coaxial cable with SMA-type plugs should be used to interface with the amplifier.

Caution: Due to the wideband nature of the unit, installation should not be attempted on a tower with transmit antennas.

If cables with the SMA-type connectors are not available, high quality adaptors are available for most coaxial connector types.

The HILNA LS has a built in bias-T capability, allowing the user to supply DC power from the RF circuitry or coaxial cables without affecting the RF signal through the main transmission path.

Caution: Due to the bias-T configuration, DC power will always be present on the RF output line.

3.2 POWER SUPPLY

The HILNA contains internal linear voltage regulators. These regulators protect the circuitry from voltage variations at the input and allow for the wide operating voltage. The power connector for the units is a mini USB four pin connector. As an option, DC power can also be applied to the RF Output port with an external bias-T. The only restrictions on the power source for the unit are:

- Capable of sourcing 150mA of current
- Capable of sourcing +5 VDC to +15 VDC

Car batteries (through a cigarette lighter adaptor), laboratory DC power supplies, or wall transformers are suitable power sources as long as the superimposed ripple is low in amplitude.

3.3 CONNECTIONS

Caution: Do not apply RF to the unit until after all cable connections are made and power has been applied.

Making the connections from the HILNA-LS-C021 is easily accomplished:

1. Connect the "RF OUT" connector on the unit to a 50 Ω coaxial cable
2. Apply power to the unit by first plugging in the 4-pin mini USB power cable into the DC power input on the unit, or through the RF Output port using an external bias-T.
3. Connect the black lead to the positive side of the power supply and connect the orange lead to the negative side of the power supply. Power is now ready to be applied to the unit.
4. Connect the RF Source to the RF Destination with a second 50 Ω coaxial cable.
5. Apply RF to the input cable assembly.

Powering down the unit is done by reversing this procedure.

Connection Summary:

- Connect the RF Output to a good load. The characteristic impedance is 50 Ω .
- Apply DC (+12 VDC Typical) at the power connector, or through the RF Output port using an external bias-T.
- Connect an RF source to the RF Input connector.



Caution: Excess drive levels at the input to the amplifier can permanently damage the unit. Under no circumstance should the RF Input level exceed +20 dBm.

3.4 ENVIRONMENTAL SPECIFICATIONS

The HILNA LS units are rated for operation from -20 to +60 °C. The enclosure is **NOT** watertight so the unit must be kept dry. It is recommended that the unit be installed in a well-ventilated area or mounted to a heat sink if the input voltage exceeds +12 VDC. The unit will run warmer as the input voltage increases.

4 PRODUCT DISPOSAL – END-OF-LIFE

Safety is a guiding principle of NuWaves Engineering. We ensure safe production and operation of our products, as well as end-of-life disposal. Improper disposal can adversely affect the environment, wildlife and human health. Please follow these guidelines when disposing of a NuWaves product:

- Do not remove the cover or any hardware
- Do not remove components from the circuit card assembly
- Do not incinerate
- Do not crush or shred
- Do not dispose of as unsorted municipal waste
- Do not export e-waste outside of the original destination country for recycling
- Utilize an e-Steward or ISO14001 certified e-waste recycler
- Consider export controls during recycler selection
- If a NuWaves product is incorporated into a larger system or sub-system, ensure that these guidelines are followed at system end-of-life

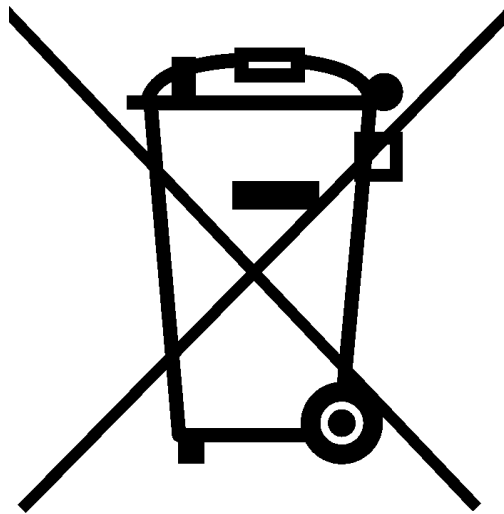

5 GETTING HELP - APPLICATIONS ENGINEERING

NuWaves Engineering offers technical support for basic configuration help and troubleshooting, Monday through Friday, 8 a.m. to 5 p.m. Eastern Time.

Technical Assistance, Application Engineering and Sales:

Email: sales@nuwaves.com

Phone: (513) 360-0800

NuWaves Home Page: <https://www.nuwaves.com/>

Product Warranty:

https://products.nuwaves.com/wp-content/uploads/NuWaves_Warranty_Repair.pdf

5.1 GENERAL INFORMATION

Copyright © 2006 – 2019 NuWaves Ltd. All rights reserved. The information contained in this user manual is copyright protected. NuWaves reserves the right to make periodic modifications and product improvements to the HILNA product line and the associated documentation.