

USER MANUAL

HIGH INTERCEPT LOW NOISE AMPLIFIER (HILNA™)

MODEL: HILNA HF AGC



Trusted RF Solutions™



NuWaves Engineering
132 Edison Drive
Middletown, Ohio 45044

PH: 513-360-0800

FAX: 513-539-8782

www.nuwaves.com

product.sales@nuwaves.com

1 HILNA™ PRODUCT LINE OVERVIEW

NuWaves' HILNA family of amplifiers is designed to achieve high RF gain while maintaining extremely low noise, and high third-order intercept point across a wide band. HILNA's robust power supply also operates over a very broad range easily allowing the unit to be integrated into systems without regard to power supply precision.

1.1 HILNA™ PRODUCT LINE HIGHLIGHTS

- High Performance - Noise, Gain, Intercept, Dynamic Range: Unique combination of extremely low noise, high gain, high output intercept, and wide band frequency coverage.
- Robust Power Supply: Operates over a very broad range of power supply voltages. Included with each amplifier is a mating power connector with cable attached.
- Enclosures:
 - HILNA HF, HILNA V1, HILNA G2V1, and HILNA GPS are housed in a black or silver anodized extruded aluminum enclosure with mounting flanges.
 - μ HILNA is housed in a miniature sleek black anodized milled aluminum enclosure.
 - HILNA LS is housed in a black anodized milled aluminum enclosure with mounting holes incorporated into the chassis
 - HILNA CX is housed in a nickel plated rugged aluminum enclosure with mounting holes incorporated into the chassis.
- Completely Characterized: The HILNA family of low noise amplifiers has been completely characterized over temperature, voltage, and frequency. The amplifiers are robust, offering significant value for the OEM user or the Systems Integrator.
- User Friendly: Reverse-voltage protection and regulator thermal shutdown provide defenses against user interface issues.
- High Reliability: NuWaves' selection of conservatively rated components provides high reliability delivering high Mean Time Between Failure (MTBF) numbers. Each HILNA is inspected to IPC-A-610 Class III quality standards.
- ESD Protection: The HILNA Amplifiers are suitable for many types of applications where ESD susceptibility is prominent. The amplifiers are designed to withstand up to 1000 V utilizing ESD waveforms described in IEC 61000 4-2.
- Applications: IF or RF Buffer Amplifier ▪ Overcome Systematic RF Losses ▪ Increase Antenna Signal Levels ▪ Military Radios ▪ RF Wideband Front-Ends ▪ RF Pre-Amp ▪ TV ▪ Final Stage

Amplifier for Low-Level Repeaters ▪ Long Cable Runs to Antenna ▪ Ultra Low Noise Applications ▪ LNA for Cellular Base Station ▪ High Linearity Systems ▪ General Purpose Amplification ▪ High Performance Receivers ▪ High Power Drive Signals for Increased Dynamic Range ▪ High Reliability RF Amplifier Applications ▪ Base Station Applications ▪ VHF/UHF Amplification ▪ Final PA for Low-Power Applications ▪ Low-Noise Transmit Driver ▪ Cable Modem ▪ Fixed Wireless ▪ Mobile Infrastructure ▪ Industrial Scientific Medical Band Applications

- Users: Engineering and Scientific Laboratories ▪ Test and Measurement Facilities ▪ OEMs of RF High End Systems ▪ Research Laboratories ▪ Communications Engineering Firms ▪ Cable TV System Engineers ▪ RF System Integrators ▪ Test Ranges ▪ Universities ▪ Antenna Design Facilities ▪ Field Service Technicians ▪ Aerospace and Defense Systems ▪ Radio and TV Engineers ▪ Amateur Radio ▪ Scientific and Consulting Agencies ▪ Radio and Wireless Communication Services ▪ Precision Equipment Repair Organizations ▪ Professional and Technical Service Institutions ▪ Military Radio & Communication Facilities product models

1.2 HILNA™ PRODUCT LINE MODELS

NuWaves offers several variants of the HILNA line-up. The HILNA family of amplifiers operates across the 2 MHz to 10 GHz frequency range. Product availability is depicted in Table 1.

Table 1: List of Models

MODEL	DESCRIPTION
HILNA HF	2 MHz to 50 MHz 30 dB Gain, Available with and without Automatic Gain Control (AGC)
HILNA V1	50 MHz to 1 GHz, 20 dB Gain
μHILNA	50 MHz to 1500 MHz, 20 dB Gain
HILNA G2V1	50 MHz to 1 GHz, 40 dB Gain
HILNA GPS	1.2 GHz to 1.6 GHz, 32 dB Gain
HILNA LS	1 GHz to 3 GHz, 50 dB Gain
HILNA CX	5 GHz to 10 GHz, [Usable 3 to 12 GHz] 35 dB to 40 dB

2 HILNA™ HF OVERVIEW

NuWaves’ HILNA HF is a broadband low noise amplifier designed to achieve high gain while maintaining low noise and a high third-order intercept point in the High Frequency (HF) bands. This high-performance module delivers 30 dB of gain across the frequency range of 2 MHz to 50 MHz with an OIP3 of +30 dBm and P1dB of +18 dBm.

The HILNA HF’s robust power supply also operates over a very broad range easily allowing the unit to be integrated into systems without regard to power supply precision. This model is also available without automatic gain control (AGC). Consult factory for details.

2.1 HILNA HF AGC OVERVIEW

The HILNA HF with AGC has two different states of operation, Manual Gain Control (MGC) mode and Automatic Gain Control (AGC) mode. With AGC enabled, the unit powers on in a fully operational default mode and there is no requirement to control the unit via serial port. The serial commands allow the user to monitor certain values, such as control state, attenuator states, RSSI level, etc.

This version of the HILNA HF consists of two stages of amplification, and two stages of attenuation. In AGC mode, the software automatically sets attenuator A (ATT A) first, and does not use ATT B until ATT A has reached its maximum setting. When AGC is disabled, the two stages of attenuation were placed in the circuit to allow flexibility in trading off cascade noise figure, versus output P1dB and OIP3 level. In MGC mode, the user can select ATT2 first, if desired. This will reduce impact on overall noise figure as attenuation is increased, but will also directly reduce the output P1dB and OIP3 level. In some operational scenarios this may be preferable.

In AGC mode, the operator has the option of setting the unit for a different AGC output level than the default level (+2 dBm). Additionally, the user can change the default AGC Attack and Decay timing.

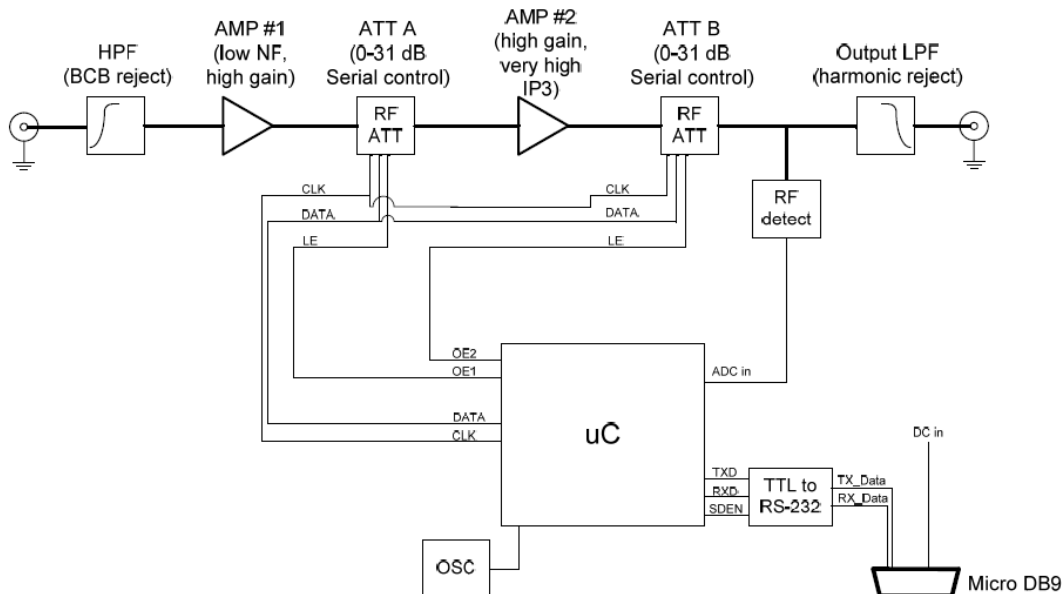

Figure 1: HILNA HF AGC Functional Diagram

2.2 HILNA HF ELECTRICAL DATA

Table 2: HILNA HF Absolute Maximum Rating

Operating Voltage	+30 VDC
RF P _{in}	+12 dBm
Operating Temperature	-20 to +60 °C
Storage Temperature	-40 to +85 °C

Table 3: HILNA HF DC Specifications

	Unit	Min	Typ	Max
Operating Voltage	VDC	+12	+12	+30
Current Consumption	mA		150	300

Table 4: MGC Mode Specifications

Parameter	Unit	ATT A	ATT B
Attenuator Control Range	dB	0 to 31.5	0 to 31.5

Table 5: AGC Mode Specifications

Parameter	Unit	AGC Mode
Default Power Out	dBm	+2
Default Attack Time	mS	100
Default Decay Time	mS	100
AGC Output	dBm	-5 (min), +10 (max)
Attack, Decay Time	mS	10 (min), 500 (max)

Table 6: HILNA HF RF Specifications

Parameter	Unit	HILNA HF		
		Min	Typ	Max
Frequency Range	MHz	2		50
Gain	dB		30	
Noise Figure	dB			5
OIP3	dBm		+30	
P1dB	dBm		+18	
VSWR In			1.5:1	
VSWR Out			1.5:1	
Reverse Isolation	dB		53	

3 HILNA HF AGC INTERFACE DEFINITIONS

The HILNA HF is RS-232 compatible and supports an interface data rate of 9600 bps. The LNA operates over a supply voltage range of +12 to +30 VDC and is reverse-voltage protected and current limited. In addition, the GND pins are provided for the supply voltage return, DC, and the serial port signal.

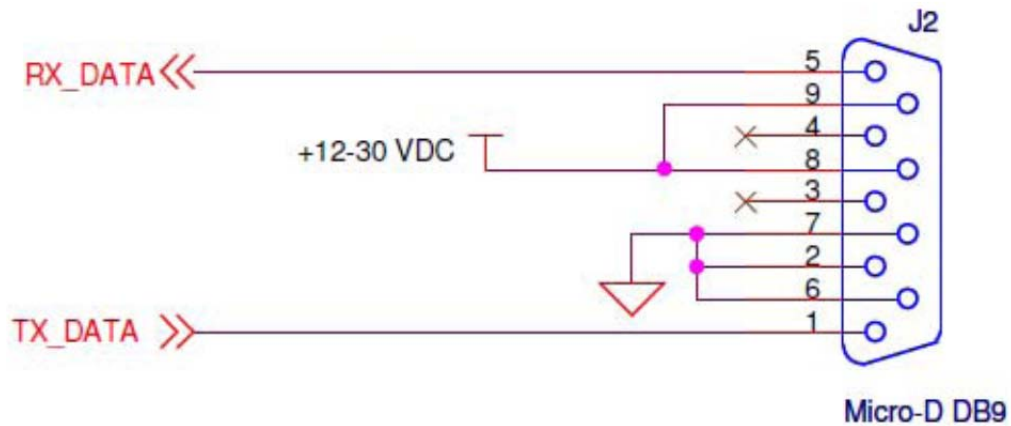

Figure 2: Interface Pinout Diagram

Table 7: PWR/CTRL Pinout Definitions

PWR/CTRL Pin No.	Pin Name	I/O	Description
1	Transmit Data	Output	Transmitted data to the host controller
2	GND	N/A	DC return ground
3	Not Connected	N/A	No internal connection
4	Not Connected	N/A	No internal connection
5	Receive Data	Input	Received data from the host controller
6	GND	N/A	DC return ground
7	GND	N/A	DC return ground
8	V Supply	Input	DC Supply Voltage, +12 to +30 VDC
9	V Supply	Input	DC Supply Voltage, +12 to +30 VDC

4 HILNA HF AGC COMMAND STRINGS

This section provides the user with the command syntax necessary to properly configure the unit for use. All commands have the following attributes;

- A command consists of a string of characters, followed by a terminating Carriage Return character (hex 0D)
- Command processing is not case sensitive.
- After receiving and processing a command the receiver sends an “OK” string, terminated with a carriage return.
- If the command is invalid, the HILNA HF returns a “??” string.
- Instruction commands are used to configure the unit’s mode of operation.

4.1 HILNA HF AGC GAIN CONTROL SELECTION

The HILNA HF can operate in either AGC or MGC mode. AGC mode delivers a nominal +2 dBm level at the output while MGC mode allows the user to determine the level output.

Table 8: Gain Control Mode Selection

Op Code	Parameter	Description
agc	On	Places receiver in AGC mode.
agc	Off	Places receiver in MGC mode.

4.1.1 AGC SETTINGS

REFVALddd is used as the reference value for the AGC. The AGC loop compares the current RSSI value to the stored REFVAL and makes a decision whether or not to adjust attenuation. The rate at which it adjusts attenuation is based on the ATACKddd and DECAYddd settings. The value of the ATACK / DECAY settings is approximately 0.5 dB per count. This determines the maximum step size that the AGC loop can make each iteration. A low ATACK / DECAY value results in longer ATACK / DECAY times, whereas a larger value results in faster times. The AGC settings are described in Table 8.

Table 9: AGC Settings

Op Code	Parameter	Range	Description
REFVAL	ddd	0000 - 1024	Sets the AGC servo loop value (given in RSSI A/D counts)
ATAK	ddd	000 - 254	Sets the AGC Attack rate
DECAY	ddd	000 - 254	Sets the AGC Decay rate
Op Code	Parameter	Range	Description
HYSTER	ddd	000 - 254	Sets the AGC Hysteresis
SPEED	d	1 - 7	Sets the Timer Scaling

The SPEEDd command controls the timer scaling. Lower speed values result in the loop running faster, whereas higher speed values result in the loop running slower. This allows for additional control over the attack and decay times. Table 9 shows the approximate time for completing one iteration for each SPEEDd setting.

Table 10: SPEEDd Iteration Times (Approximate)

SPEED	Time (mS)
1	0.61
2	0.60
3	2.22
4	4.44
5	8.85
6	17.70
7	70.90

The HYSTERddd command defines the amount of change needed in the RSSI value before the AGC loop makes any change to attenuation. The value for the HYSTER is approximately 16 counts per 0.5 dB (e.g. HYSTER032 would equate to an approximate 1 dB change required before any attenuation is added or removed). This setting prevents the AGC loop from constantly adding or removing attenuation due to a small signal level change. Table 10 lists SPEED, ATACK, and DECAY settings for 4 different attack / decay times.

Table 11: AGC settings for various attack / decay times

Time (mS)	Speed	Attack	Decay
10	SPEED3	ATAACK018	DECAY018
100	SPEED6	ATAACK009	DECAY010
250	SPEED6	ATAACK003	DECAY003
500	SPEED6	ATAACK002	DECAY002

These times are based on a 30 dB delta on the incoming signal level. Initial approximations for attack / decay times can be calculated with some knowledge of the incoming signal. To approximate the attack time, apply the following formula:

$$\mathit{attack\ time} = \mathit{speed\ time\ (mS)} * 2 * \frac{\mathit{incoming\ signal\ change\ (\Delta\ dB)}}{\mathit{attack\ setting}}$$

The same formula also applies to decay times. For example, with settings SPEED6, ATACK010, and a Δ dB of 40, we see that:

$$\mathit{attack\ time} = 17 * 2 * \frac{40}{10} = 136\ mS$$

Note that these calculations are close approximations and do not take into account the processor overhead or decisions made by the estimator as to how much attenuation change to make.

4.1.2 MGC SETTINGS

In MGC mode, the user has the ability to control the level over a range of 60 dB. The default setting is 0000. Each count represents approximately 0.5 dB worth of attenuation. For example, the command string “ATTA0044” sets Attenuator 1 to approximately 22 dB of attenuation. Table 11 illustrates the MGC attenuator settings.

Table 12: MGC Attenuator settings

Op Code	Parameter	Range	Description
atta	dddd	0000 - 0063	Select Manual Gain for Attenuator 1
attb	dddd	0000 - 0063	Select Manual Gain for Attenuator 2

4.1.3 HILNA HF AGC CONFIGURATION SETTINGS

The following are the factory default settings and are present upon initialization of the receiver:

- Automatic Gain Control Mode ON (AGC on)
- +2 dBm nominal output
- Attack / Decay times of 100 mS

Table 13: Configuration Commands

Op Code	Parameter	Description
con	def	Reset configuration to stored default
con	sto	Store current configuration as startup settings
stat	?	Returns current settings

When changes are made to the system settings, they are only valid as long as the unit remains powered on. To keep desired settings, the CONSTO command will store the current settings to memory, and the stored settings will be retained and used on the next startup. Note that any settings saved using CONSTO will overwrite the factory settings.

5 HILNA HF MECHANICAL SPECIFICATIONS

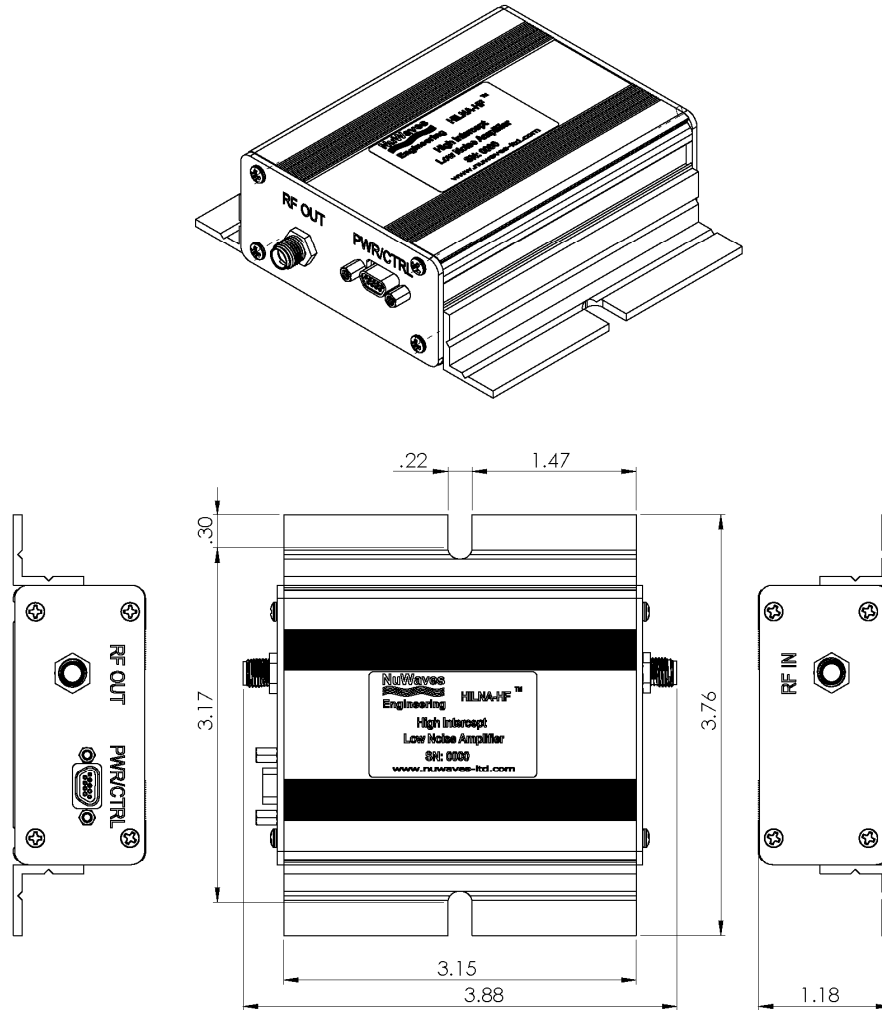

Figure 3: HILNA HF Mechanical Outline with Mounting Flanges

Table 14: HILNA HF Mechanical Specifications

RF Bulkhead Connector	SMA female
RF Input and Output Mating Connector	SMA male
DC Power Connector	Micro-DB9
Dimensions (L x W x H)	3.15" x 2.50" x 1.18"
Weight	5.00 oz.

6 INSTALLING, CONNECTING, AND USING THE HILNA AMPLIFIER

HILNA amplifiers have been designed to be highly reliable under the specified operating conditions. The following installation and interfacing guidelines should be followed to prevent damage to the RF module.

Caution: The HILNA amplifier contains components that are sensitive to Electro-Static Discharge (ESD). The use of wrist strap, mats, and ground straps should be adhered to during the installation process.



6.1 CABLING

The HILNA HF is equipped with high-performance RF connectors. Gold plated SMA-type receptacles are used because they perform very well across the usable frequency range of the unit. For optimal performance, a high-quality 50 Ω coaxial cable with SMA-type plugs should be used to interface with the amplifier.

Caution: Due to the wideband nature of the unit, installation should not be attempted on a tower with transmit antennas.

If cables with the SMA-type connectors are not available, high quality adaptors are available for most coaxial connector types.

6.2 POWER SUPPLY

The HILNA HF contains internal linear voltage regulators. These regulators protect the circuitry from voltage variations at the input and allow for the wide operating voltage. The power connector for the units is an industry standard Micro-DB9 connector. The only restrictions on the power source for the unit are:

- Capable of sourcing 300 mA of current
- Capable of sourcing +12 VDC to +30 VDC

Car batteries (through a cigarette lighter adaptor), laboratory DC power supplies, or wall transformers are suitable power sources as long as the superimposed ripple is low in amplitude.

6.3 CONNECTIONS

Caution: Do not apply RF to the unit until after all cable connections are made and power has been applied.

Making the connections from the HILNA HF is easily accomplished:

1. Connect the "RF OUT" connector on the unit to a 50 Ω coaxial cable
2. Apply power to the unit by first plugging in the power cable sent with the unit into the DC power input.
3. Connect the power leads as directed in Table 7. Power is now ready to be applied to the unit.
4. Connect the RF Source to the RF Destination with a second 50 Ω coaxial cable.

5. Apply RF to the input cable assembly.

Powering down the unit is done by reversing this procedure.

Connection Summary:

- Connect the RF Output to a good load. The characteristic impedance is 50 Ω .
- Apply DC (+12 VDC to +30 VDC) at the power connector.
- Connect an RF source to the RF Input connector.



Caution: Excess drive levels at the input to the amplifier can permanently damage the unit. Under no circumstance should the RF Input level exceed +20 dBm.

6.4 ENVIRONMENTAL SPECIFICATIONS

The HILNA HF units are rated for operation from -20 to +60 °C. The enclosure is **NOT** watertight so the unit must be kept dry. It is recommended that the unit be installed in a well-ventilated area or mounted to a heat sink if the input voltage exceeds +20 VDC. The unit will run warmer as the input voltage increases.

7 PRODUCT DISPOSAL – END-OF-LIFE

Safety is a guiding principle of NuWaves Engineering. We ensure safe production and operation of our products, as well as end-of-life disposal. Improper disposal can adversely affect the environment, wildlife and human health. Please follow these guidelines when disposing of a NuWaves product:

- Do not remove the cover or any hardware
- Do not remove components from the circuit card assembly
- Do not incinerate
- Do not crush or shred
- Do not dispose of as unsorted municipal waste
- Do not export e-waste outside of the original destination country for recycling
- Utilize an e-Steward or ISO14001 certified e-waste recycler
- Consider export controls during recycler selection
- If a NuWaves product is incorporated into a larger system or sub-system, ensure that these guidelines are followed at system end-of-life

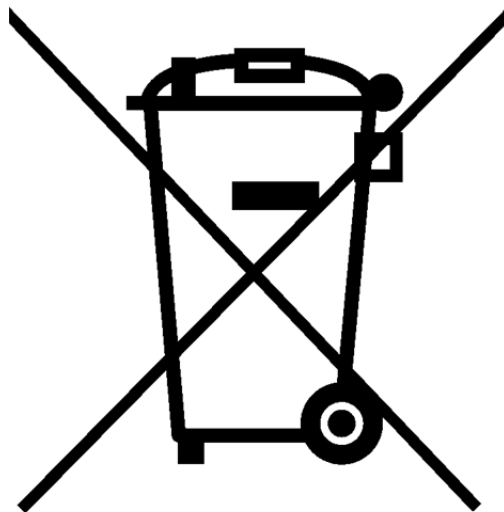

8 GETTING HELP - APPLICATIONS ENGINEERING

NuWaves Engineering offers technical support for basic configuration help and troubleshooting, Monday through Friday, 8 a.m. to 5 p.m. Eastern Time.

Technical Assistance, Application Engineering and Sales:

Phone: (513) 360-0800

Email: product.sales@nuwaves.com

NuWaves Home Page: <https://www.nuwaves.com/>

Product Warranty:

https://products.nuwaves.com/wp-content/uploads/NuWaves_Warranty_Repair.pdf

8.1 GENERAL INFORMATION

Copyright © 2006 – 2019 NuWaves Ltd. All rights reserved. The information contained in this user manual is copyright protected. NuWaves reserves the right to make periodic modifications and product improvements to the HILNA product line and the associated documentation.