

# USER MANUAL

## GPS RF FRONT END

PART NUMBER:  
NW-RF-GPS-FE

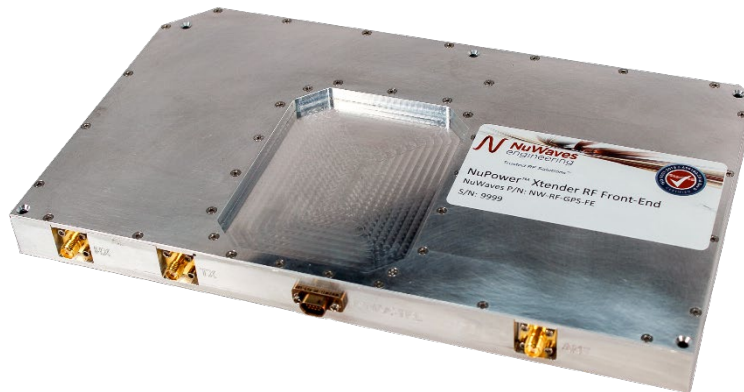

NuWaves Engineering  
132 Edison Drive  
Middletown, Ohio 45044  
Tel: 513-360-0800

[www.nuwaves.com](http://www.nuwaves.com)  
[product.sales@nuwaves.com](mailto:product.sales@nuwaves.com)

---

## 1 NUWAVES RF FRONT END PRODUCT LINE OVERVIEW

---

NuWaves' family of solid state RF power amplifier (PA) modules, low noise amplifiers (LNAs), and high performance filters, are designed to meet the demanding needs of the Aerospace & Defense, Industrial, and Commercial markets.

### 1.1 RF FRONT END PRODUCT LINE HIGHLIGHTS

---

- High Performance: Unique combination of broadband coverage, miniature form factors, and high efficiency.
- Enclosures: The GPS RF Front End's internal filters are housed in a silver-and-nickel plated aluminum chassis, all enclosed in a light-weight aluminum chassis with incorporated mounting holes.
- User Friendly: Reverse-Voltage & Over-Voltage protection and regulator thermal shutdown provide defenses against user interface issues.
- High Reliability: NuWaves' selection of conservatively rated components provides high reliability. Each GPS RF Front End is inspected to IPC-A-610 Class II quality standards. NuWaves' Quality Management System is AS9100:2016 Rev D and ISO 9001:2015 certified.
- Applications: RF Telemetry, RF Communication Systems, Unmanned Aircraft Systems (UAS), Unmanned Ground Vehicles (UGV), Satellite Terminals, Software Defined Radios

## 2 GPS RF FRONT END OVERVIEW

The NuWaves GPS RF Front End is a highly efficient, high transmit/receive gain module to boost performance of data links. This high-performance RF front end is a powerful combination of the NuPower 13G05A RF power amplifier, low noise amplifiers, a high isolation diplexer between the transmit and receive paths with rejection of GPS L1 band, and band-reject filters.

This module accepts a nominal 0 dBm (1 mW) RF input and provides 45 dB of transmit gain from 1626.5 to 1675 MHz and provides 47 dB of receive gain from 1518 to 1559 MHz. With a typical isolation of 80dB between 1518-1559 MHz and 1626.5-1675 MHz bands, the NuWaves GPS RF Front End enables full duplex operation. It supports both constant envelope and complex waveforms such as APSK, QAM, DVB-T, etc.

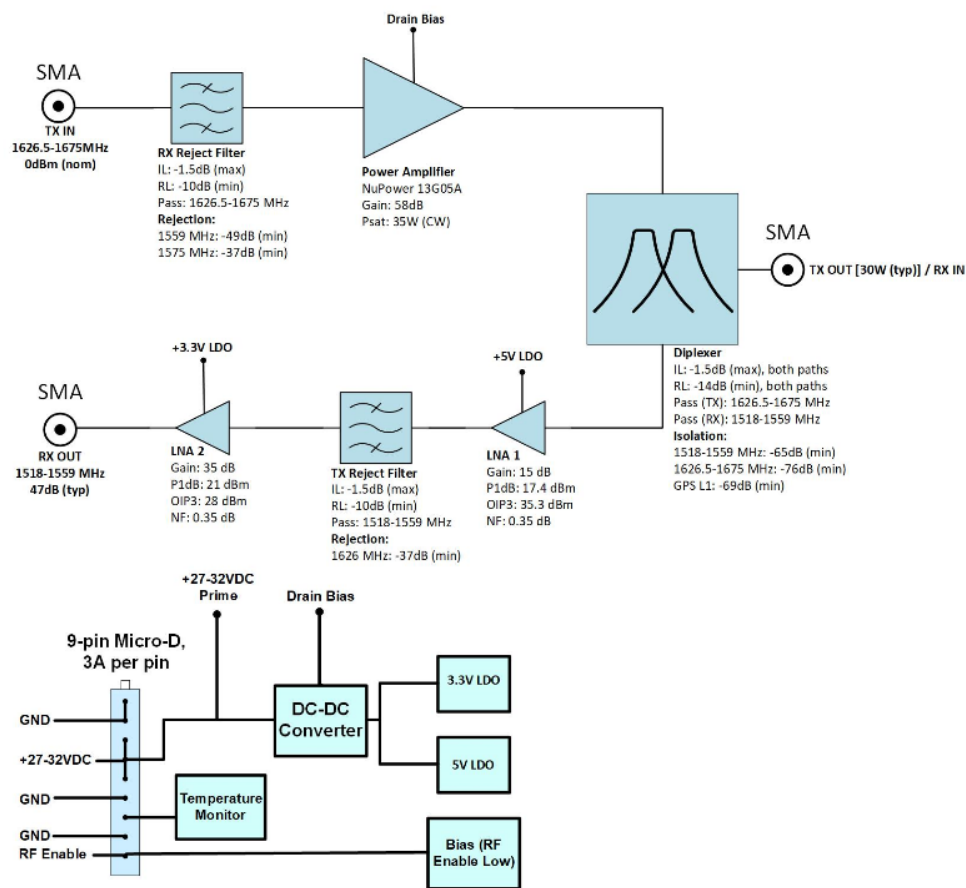

Figure 1: GPS RF Front End Block Diagram

### 2.1 GPS RF FRONT END SPECIFICATIONS

The subsequent tables in this section outline the GPS RF Front End's performance specifications.

Table 1: GPS RF Front End Electrical Specifications - Operational

Parameter	Specification
Transmit Frequency Range	1626.5 to 1675 MHz
Receive Frequency Range	1518 to 1559 MHz
Operating Voltage	+27VDC to +32VDC
Operating Current	3.25A @ 0dBm Input
Module Efficiency	35% (typ)

**Table 2: GPS RF Front End Electrical Specifications - Transmit**

Parameter	Specification
RF Output Power	20W (min), 30W (typ), Pin=0dBm, CW
P1dB	31dBm (typ)
Small Signal Gain	57dB (typ)
Input VSWR	1.5:1 (typ)
Nominal Input Drive	0 dBm
Quiescent Current (unbiased)	140 mA
Quiescent Current (biased)	750 mA
2 <sup>nd</sup> Harmonic	-70 dBc (typ)
Module Efficiency	35% (typ)

**Table 3: GPS RF Front End Electrical Specifications - Receive**

Parameter	Specification
Receive Gain	47dB (typ)
Receive Gain Flatness	1dB (typ)
Receive Current	140 mA
Noise Figure	1.7 dB (typ)

**Table 4: GPS RF Front End Environmental Specifications**

Operating Conditions	Specification
Operating Temperature – Ambient	-40 to +60 °C
Operating Temperature – Baseplate	-40 to +85 °C
Storage Temperature	-55 to +85 °C

## 2.2 GPS RF FRONT END MECHANICAL SPECIFICATIONS

**Table 5: GPS RF Front End Mechanical Specifications**

Parameter	Specification
Interface Connector	Micro-D, 9-pin Socket
RF Connectors, Input/Output	SMA Female
Dimensions (LxWxH)	10.25" x 6.00 x 0.80
Weight	47 oz.

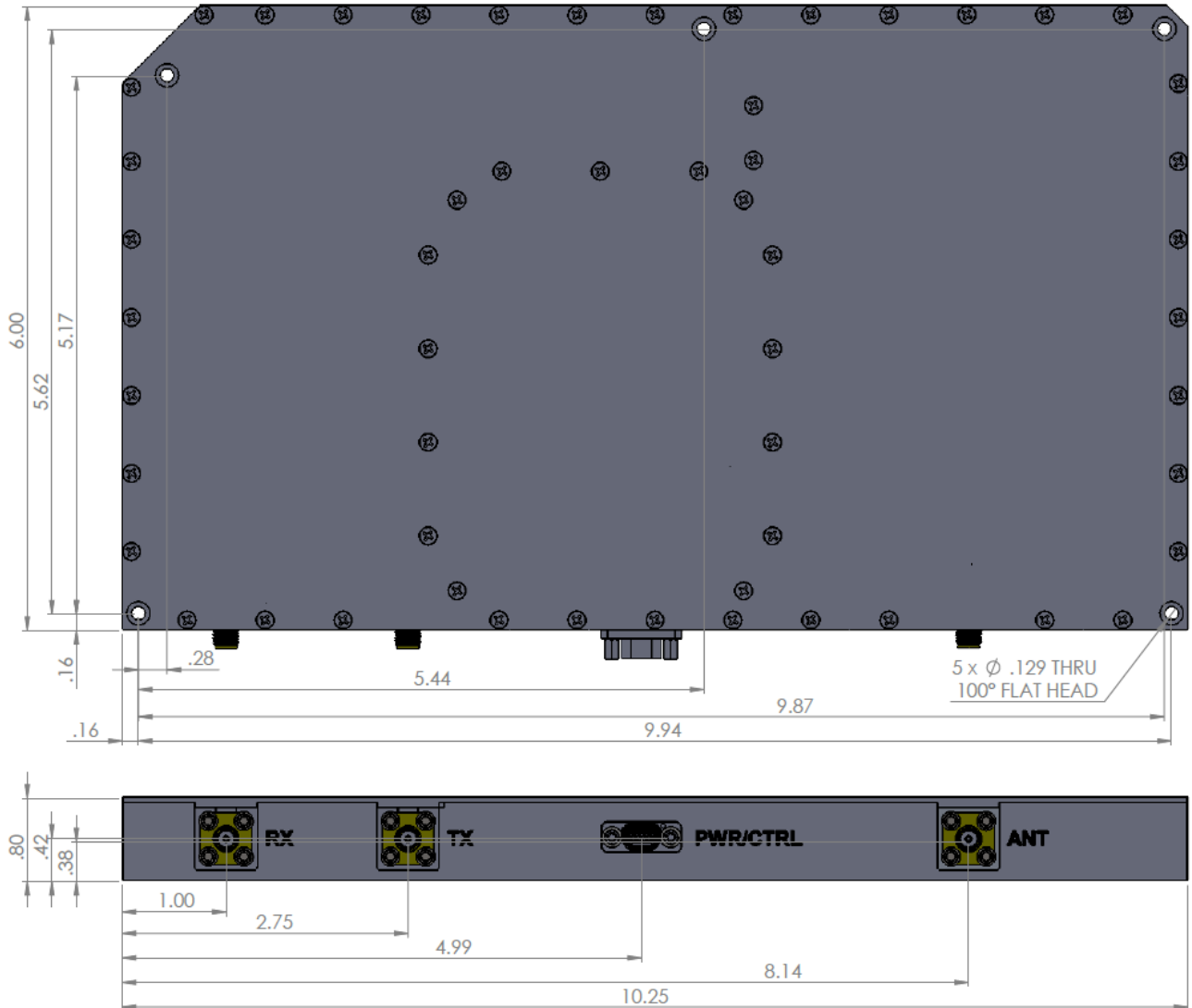

Figure 2: GPS RF Front End Mechanical Outline

## 2.3 HEAT SINKING



The use of external heat-sinking is required especially for those applications requiring high duty cycle operation (e.g. continuous wave) or for extended on-time testing. Operation without a proper heat sink under these conditions will cause permanent damage to the product and will void the product warranty. The max operating temperature is 85° C (baseplate).

## 3 SET UP AND OPERATION

This section provides specific details for proper operation of the GPS RF Front End module. Following

these guidelines will prevent damage to the power amplifier or external equipment.

---

### 3.1 POWER SUPPLY REQUIREMENTS

---

To operate the GPS RF Front End, ensure that the power supply has adequate overhead to source the current demand of the RF power amplifier. The power supply source must provide a typical voltage of +28 VDC with greater than 5 amps capability.

---

### 3.2 CONNECTING A PROPER LOAD TO THE ANTENNA TERMINAL

---

To prevent damage to the GPS RF Front End, the antenna terminal must be terminated into a 50  $\Omega$  load. Examples of a proper load include:

- Directly connecting to an antenna specified for the frequency range (960 MHz to 1390 MHz). Connecting to an inappropriate antenna may result in damage to the front end module.
- Connecting to a proper antenna through a 50  $\Omega$  transmission line or coaxial cable. Avoid using damaged cables or corroded connectors while attaching the unit to an antenna.
- Terminating the antenna terminal into a 50  $\Omega$  power attenuator with minimum 20 dB attenuation.
- Connecting to a load capable of dissipating the RF power from the front end module. Loads capable of handling 50 Watts (min) are recommended.

---

### 3.3 POWERING-UP THE GPS RF FRONT END

---

The GPS RF Front End must be terminated to a proper load before power is applied. Refer to Section 3.2 for the specifications of the proper load. After the front end is properly terminated, the interface cable can be connected to the unit and power can be applied. The front end is now ready for operation.

---

### 3.4 TRANSMIT TURN-ON TIME

---

The GPS RF Front End is at full power approximately 1  $\mu$ S after the RF Enable line goes low (ground). Therefore, transmit data can be applied to the input after 1  $\mu$ S without loss of data.

---

## 4 HARDWARE INTERFACE

---

- The TX IN connector is SMA (female)
- The RX OUT connector is SMA (female)
- The ANT connector is SMA (female)

The pin-out definitions for the 9 pin Micro-D socket connector are provided in Table 6. In a typical installation, the GPS RF Front End module is mated to a host controller board via a cable harness.



The RF Out SMA connector is the antenna connection. This connection should always be loaded into 50  $\Omega$ , otherwise the front end could be damaged.

## 4.1 INTERFACE CABLE HARNESS

The cable harness that connects the host controller to the 9 pin Micro-D connector of the GPS RF Front End is made up of 9 wires.

**Table 6: GPS RF Front End Interface Pin-Out Definitions Pin No. Pin Name I/O Description**

Pin No.	Pin Name	I/O	Description	Logic Voltage Range	Logic Type
3, 4, 5	V Supply	I	Primary Power (+28 VDC)	-	-
1, 2, 6, 8	GND	I	Signal and Power Ground	-	-
7	Temp Flag	O	Over-temp Indicator (Low = Temperature Fault; High = No Fault)	High = +3.85V to +5V Low = 0V to 0.4V	+5V CMOS
9	RF Enable	I	Transmit Control	High = +3.85V to +5V Low = 0V to 1.65V	+5V CMOS

Figure 3: Micro-D Socket Locations

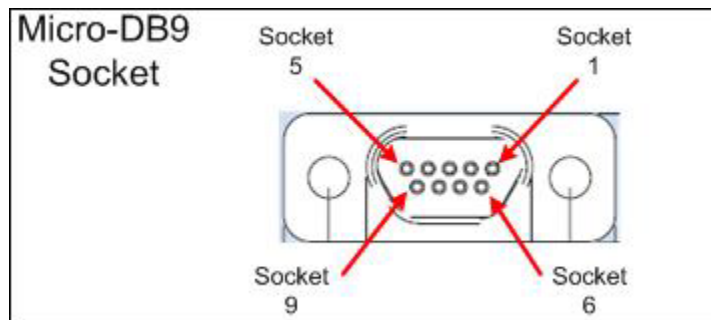

Note: with respect to orientation depicted in Figure 2 above

## 4.2 DC POWER

The nominal supply voltage for the GPS RF Front End is +28 VDC; The acceptable supply voltage range is +27 to +32 VDC. If a voltage above 32VDC is applied, the drain bias to internal amplifiers will be removed and the transmit path will be non-operational. Input voltage below +27VDC will result in degraded RF performance and specifications are not guaranteed below the specified +27 to +32VDC range.

## 4.3 GROUND

The signal and power grounds are tied together in the GPS RF Front End module.

## 4.4 RF ENABLE

This signal is the logic control input that designates whether the unit is in transmit or standby mode. The RF Enable line is pulled high internally placing the GPS RF Front End module in *standby* mode. If the pin is left floating (i.e. not connected), the unit will default to *standby* mode.

Grounding the pin (i.e. a voltage below +0.2 VDC) places the unit in *transmit* mode. The user can either connect the RF Enable line to pins 1, 2, 6 & 8 on the CTRL/PWR interface connector, or an open drain logic line capable of sinking 500  $\mu$ A to place the unit in *transmit* mode.

## 4.5 TEMP FLAG

This signal is an output to indicate an over-temperature condition in the GPS RF Front End. A logic high (+5 VDC) indicates normal operation, while a logic low (0 VDC) indicates an over-temperature condition. The GPS RF Front End incorporates internal logic circuitry that turns off the DC bias to the RF transistors.



Caution: The amplifier should be shut down and allowed to cool off when the overtemperature flag is set low to avoid damage to the module.

---

## 5 PRODUCT DISPOSAL – END-OF-LIFE

---

Safety is a guiding principle of NuWaves RF Solutions. We ensure safe production and operation of our products, as well as end-of-life disposal. Improper disposal can adversely affect the environment, wildlife and human health. Please follow these guidelines when disposing of a NuWaves product:

- Do not remove the cover or any hardware
- Do not remove components from the circuit card assembly
- Do not incinerate
- Do not crush or shred
- Do not dispose of as unsorted municipal waste
- Do not export e-waste outside of the original destination country for recycling
- Utilize an e-Steward or ISO14001 certified e-waste recycler
- Consider export controls during recycler selection
- If a NuWaves product is incorporated into a larger system or sub-system, ensure that these guidelines are followed at system end-of-life

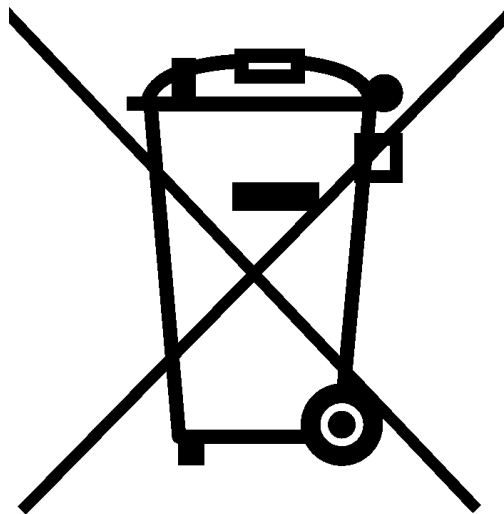

---

## 6 GETTING HELP – APPLICATIONS ENGINEERING

---

NuWaves RF Solutions offers technical support for basic configuration help and troubleshooting, Monday through Friday, 8 a.m. to 5 p.m. Eastern Time.

Technical Assistance and Application Engineering:

Email: [product.sales@nuwaves.com](mailto:product.sales@nuwaves.com)

Phone: (513) 360 - 0800

NuWaves Home Page: <https://www.nuwaves.com/>

Product Warranty:

[https://products.nuwaves.com/wp-content/uploads/NuWaves\\_Warranty\\_Repair.pdf](https://products.nuwaves.com/wp-content/uploads/NuWaves_Warranty_Repair.pdf)

---

### GENERAL INFORMATION

---

Copyright © 2006 – 2021 NuWaves Ltd. All rights reserved. The information contained in this user manual is copyright protected. NuWaves reserves the right to make periodic modifications and product improvements to the GPS RF Front End product line and the associated documentation.