

## Application Note AN-004: 90 Degree Hybrid Coupled Power Amplifier Pros and Cons

### Introduction

Power Amplifiers (PAs) are commonplace in Radio Frequency (RF) systems, extensively used in applications consisting of over-the-air wireless communications. Wireless communications is a broad market and PAs fill a wide array of those applications. Due to the broad range of applications, PA design techniques must be chosen carefully for each application specific scenario. Single-ended PAs have limitations that restrict their practicality in many applications, especially where higher output power capability is required. For this reason, the hybrid coupled PA technique is an important power amplifier topology to understand for both PA designers and users. A traditional hybrid coupled amplifier topology is shown in Figure 1, where two amplifiers are operated in parallel utilizing 3 dB, 90-degree hybrid couplers. These types of amplifiers are called 90-degree hybrid coupled or quadrature-coupled amplifiers. The amplifiers are operated in quadrature, meaning they operate 90 degrees out of phase in respect to the voltage component of the RF signal. Quadrature hybrid coupled PAs offer technical advantages over single ended PAs, making them ideal for many wireless RF communication systems.

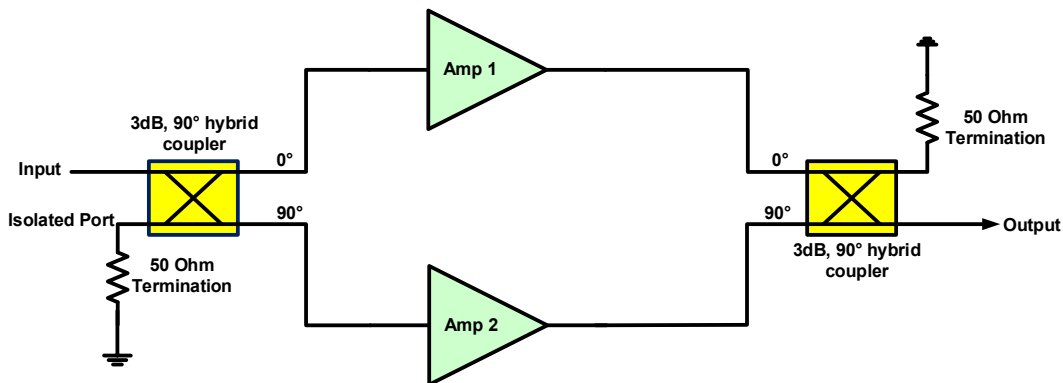

**Figure 1: 90-degree hybrid coupled amplifiers combine to provide 3dB additional output power capability.**

### What is a Quadrature Hybrid Coupled Amplifier?

The 90-degree hybrid coupled amplifier technique utilizes 90-degree hybrid couplers and two amplifiers in a power combining configuration for a 3dB increase in output power capability. Hybrid couplers are 4-port passive devices that are configurable as signal splitters or signal combiners. A detailed block diagram is provided in Figure 2 depicting the signal amplitudes and phases throughout the RF lineup.

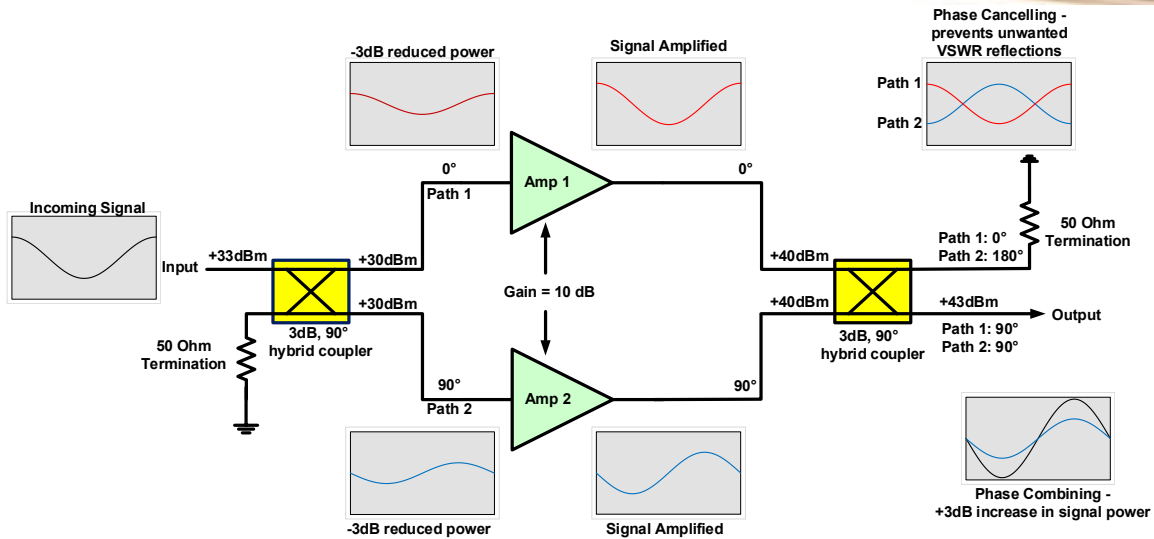

**Figure 2: Phase combining and phase cancellation provide advantages over single ended amplifier topologies using 3dB, 90-degree hybrid couplers.**

The 3dB, 90° hybrid coupler, as shown at the input (left) of Figure 2, can be used to split an input signal into two equal amplitude paths where the signal voltages are separated in phase by 90 degrees. The fourth port is the isolation port that terminates Voltage Standing Wave Ratio (VSWR) reflections into a 50 Ohm load resistor, maintaining a high-isolation between each amplifier. The mismatch reflections from each amplifier are not seen by the other amplifier, thereby providing a 50 Ohm match at the input port of the hybrid coupler. Mismatch reflections are both terminated into the isolation port and cancelled at the input port due to a 180-degree phase mismatch at the input.

After the signal is split and each signal is amplified by the amplifiers a second 3dB, 90° hybrid coupler is used as a signal combiner at the output. The output hybrid coupler re-combines the equal amplitude and 90 degree out of phase signals such that they combine in-phase to produce a 3dB increase in signal amplitude at the output port. For example, if each amplifier is operating at a saturated output power of +40 dBm (10 Watts) as shown in Figure 2, then the two +40 dBm signals re-combine in-phase to produce +43 dBm (20 Watts) of output power at the output port of the hybrid coupler.

A +3 dB increase in output power is realized with hybrid coupled amplifiers which would otherwise only be achievable by using higher output power devices when using a single ended amplifier design.

## 90-Degree Hybrid Coupler Pros/Cons

The 90-degree hybrid coupled amplifier and single ended amplifiers both offer many tradeoffs to be carefully considered by the designer or user when selecting a PA technique for a specific application. Table 1 provides a comparison of 90-degree hybrid coupled amplifiers and singled ended amplifiers.

**Table 1: Comparison of 90 Degree Hybrid Coupled Amplifiers and Single Ended Amplifiers**

Amplifier Technique	Pros	Cons
<b>90 Degree Hybrid Coupled</b>	<ul style="list-style-type: none"> <li>• +3dB increase in output power</li> <li>• Improved return loss</li> <li>• Ease of matching output power, efficiency, or linearity</li> <li>• VSWR protection</li> <li>• + 3 dB increased in P1dB</li> <li>• + 3dB increase in OIP3</li> <li>• Improved linearity</li> <li>• Increased harmonic and intermodulation rejection</li> <li>• Easily modified</li> <li>• Less susceptible to gain ripple</li> <li>• Robust</li> <li>• Improved thermal spreading</li> </ul>	<ul style="list-style-type: none"> <li>• Increased cost of additional amplifier and bias circuitry</li> <li>• Increased size requirements</li> <li>• Amplifier bandwidth is limited to hybrid coupler bandwidth</li> <li>• Potentially large termination resistors</li> </ul>
<b>Single Ended</b>	<ul style="list-style-type: none"> <li>• Lower selling cost</li> <li>• Small size is achievable</li> <li>• Higher efficiency</li> </ul>	<ul style="list-style-type: none"> <li>• VSWR protection must be added</li> <li>• Harmonic filtering must be added</li> <li>• Longer design time vs using hybrid couplers to increase output power</li> </ul>

Noteworthy advantages of 90-degree hybrid PAs are the improved return loss and VSWR protection provided by the phase cancellation of reflected signals at the input port of the input coupler and the output port of the output coupler. A diagram is provided in Figure 3 showing how the signal travels through the input coupler providing improved return loss at the input port.

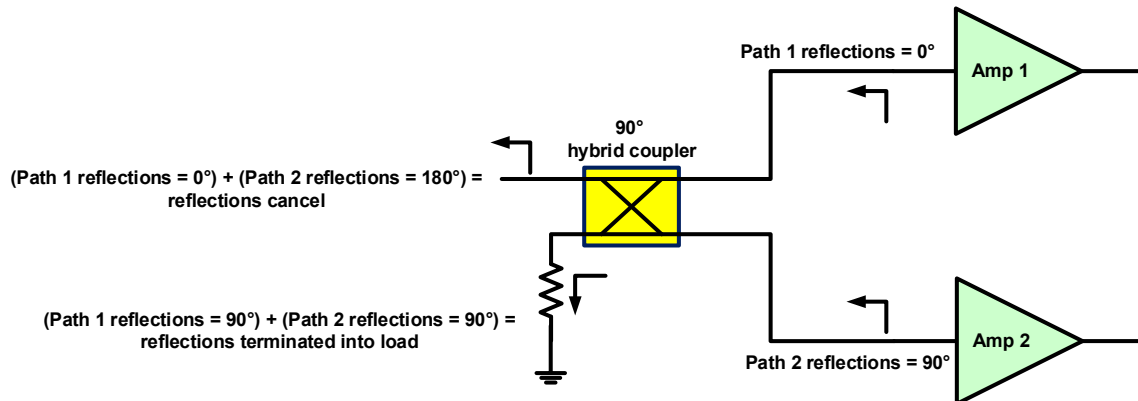
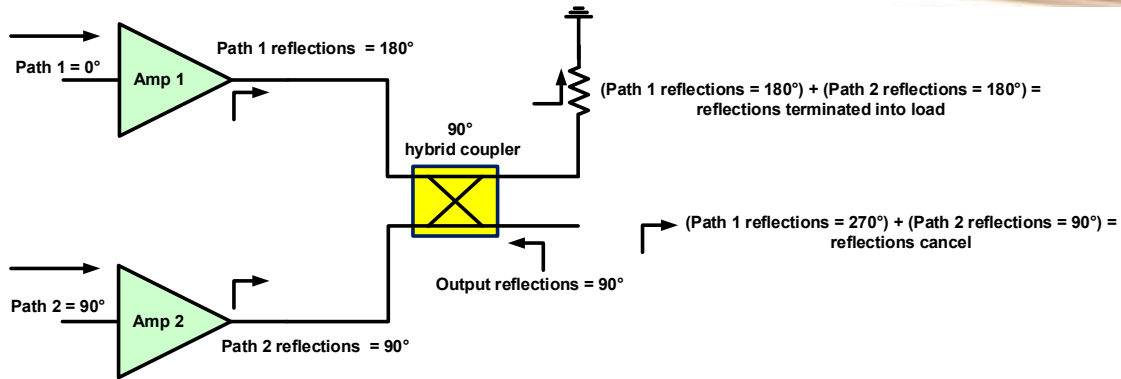

**Figure 3: The 90-degree hybrid coupler provide 50 Ohm match at the input port.**

The input signal passes through the 90-degree hybrid coupler such that Path 1 is 0° phase shifted and Path 2 is 90° phase shifted. Mismatch reflections at the amplifier inputs are reflected back to the input coupler where the reflections from each amplifier become 180 degrees out of phase and cancel at the input port. The reflected signal from Path 1 is 0° phase shifted at the input port of the hybrid coupler, whereas, the Path 2 reflected signal is 180° phase shifted at the input port. At this point Path 1 and Path 2 signals are 180° out of phase and will cancel out. This phase cancelling benefit allows any prior circuitry in the RF chain, such as driver amplifiers, transceivers, and radios, to be well isolated from the reflections from Path 1 and Path 2 while being well matched into the 50 Ohm termination of the 90-degree hybrid coupler. The result of this is an improved return loss. This minimizes large swings in gain ripple caused by poor impedance matching between the amplifier and any preceding RF circuitry.

At the isolation port, the reflections from the path 1 and path 2 amplifiers combine in phase, but are isolated from each amplifier stage as the combined reflection is terminated into a 50 Ohm load connected to the isolation port. This provides a high isolation between each amplifier, preventing each amplifier from seeing reflections from the other amplifier which would otherwise create additional ripple.

The amplifier outputs are protected from high VSWR conditions such as open and short when a 90-degree hybrid coupled amplifier technique is implemented. Similar to the input the reflections, the output VSWR reflections are cancelled at the output port of the output hybrid coupler. The output reflections and phase cancelling results are illustrated in Figure 4.



**Figure 4: VSWR protection is achieved utilizing 90-degree hybrid couplers.**

Path 1 and Path 2 signals are 90 degrees out of phase as they are amplified by each amplifier and re-combine at the hybrid coupler output port at a 90-degree phase shift from the originating input signal. Output reflections due to mismatch or open and short conditions reflect back through the hybrid coupler towards the PAs, undergoing an additional 90-degree phase change. As the output signal of 90 degrees passes back through the hybrid coupler, Path 1 reflections are phase shifted a total of 180 degrees and Path 2 reflections remain at a total phase shift of 90 degrees when compared to the original input signal. These reflections will pass back through the hybrid coupler once more as they move towards the output port and antenna, and once again undergoing a 90-degree phase shift. At the output port, the 180-degree Path 1 reflections are phase shifted 90 degrees such that Path 1 reflections are 270-degree total phase shifted at the output port. Path 2 reflections remain unchanged at 90-degrees passing through the 0-degree port of the hybrid coupler. At the output port the Path 1, 270-degree phase shifted signal and the Path 2, 90-degree phase shifted signal cancel each other out as they are 180 degrees out of phase. A great 50 Ohms match is achieved at the output port for this reason. In cases where output VSWR are important, a hybrid coupled PA maintains a near 50 Ohm VSWR without the need for large matching networks to transition the PA output impedance to 50 Ohms. At the isolated port the signals of Path 1 and Path 2 are in phase at 180 degrees, but are terminated into the 50 Ohm load. These benefits allow very high output VSWR conditions to be tolerated including open and short load conditions without the inclusion of VSWR protection circuitry such as isolators, circulators, and VSWR detection.

Due to the 50 Ohm match seen at the input port of the input coupler and the output port of the output coupler, the PA can be matched specifically for parameters such as maximum efficiency, output power, gain, and linearity. These parameters typically require tradeoffs with return loss and gain ripple, but the inherent return loss improvement of hybrid couplers minimizes the need to balance these parameters. The input and output VSWR of the PA match can be intentionally poor to achieve a desired performance in efficiency, output power, gain, and linearity.

As discussed previously, the saturated output power is increased by +3dB in a hybrid coupled configuration. This characteristic yields further benefits by improving the P1dB and OIP3 by +3dB compared to the single amplifier performance. A hybrid coupled amplifier is a quick solution when improved output power, P1dB, OIP3, or linearity are required. For example, to meet our customer's requirements, NuWaves has hybrid coupled a quantity of 4 NuWaves NuPower L60T01 COTS modules to achieve up to 200 Watts of RF output power. This significantly reduced the development time by reducing the need for large engineering design efforts for a custom higher

power solution which can be costly and timely. The amplifier design approach and measured output power results are presented below in Figure 5 and Figure 6 respectively.

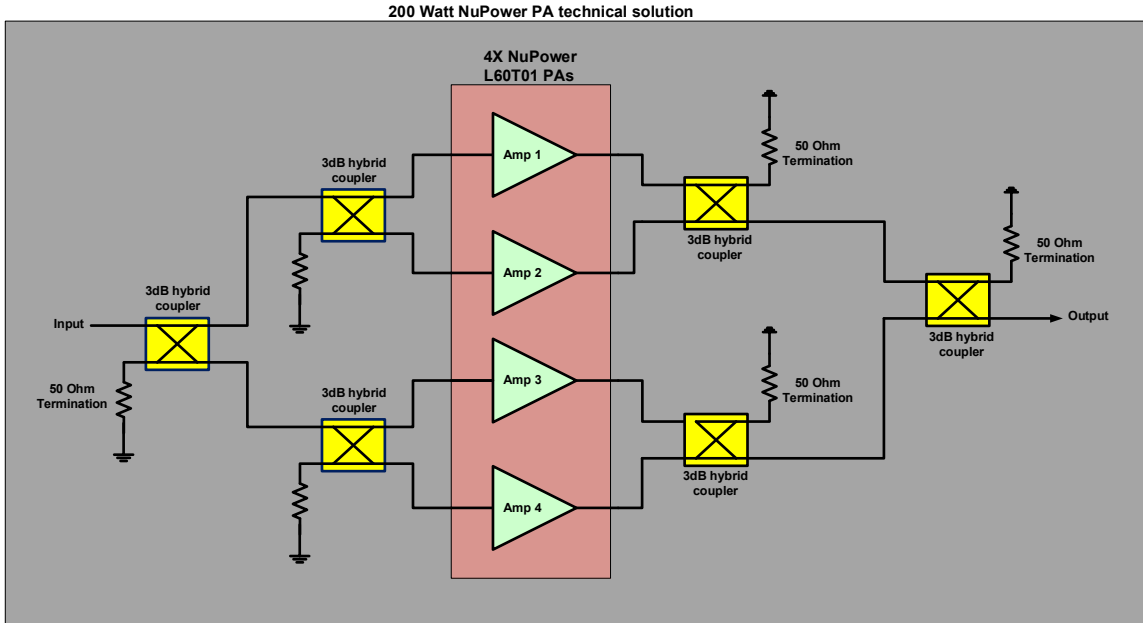

**Figure 5: Quick turn technical solution utilizing NuPower COTS amplifiers in hybrid configuration.**

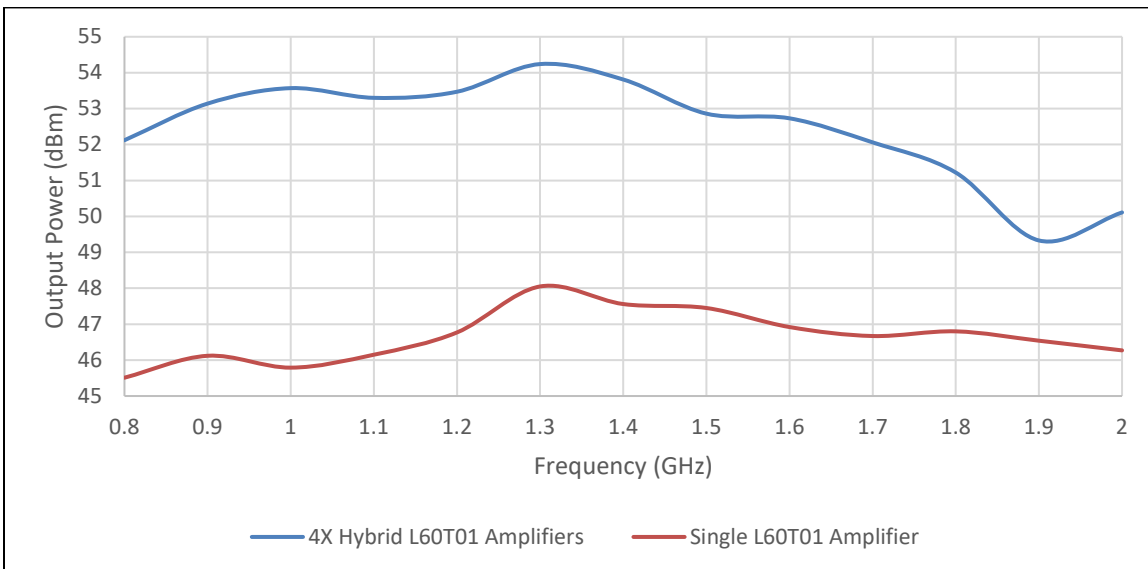

**Figure 6: 4x hybrid coupled NuPower PA vs single NuPower L60T01 increases output power from 63 Watts up to 265 Watts at 1.3 GHz.**

All COTS items were utilized in this design such that no new engineering development time was spent designing a new PA. The costs to design a single amplifier to meet these requirements can be



expensive with longer development time due to the additional up-front testing and troubleshooting. A faster turnaround time from concept to production is easily realized with a hybrid coupled amplifier.

Improved thermal spreading occurs in hybrid coupled PAs. This benefits designers and end users by reducing heatsink requirements and maximizing individual device Mean Time Between Failure (MTBF). The amplifiers in a hybrid coupled design are spaced far enough apart that the thermal load at any given point is reduced. This increases the rate that heat can be removed with the heatsink as the heat is more evenly distributed.

The size and weight of the design increases as amplifiers are added in a hybrid coupled approach. Design size begins to increase with hybrid coupled PAs due to the necessary inclusion of hybrid couplers, load resistors, additional PAs, and supporting bias circuitry. A single ended PA offers the smallest size, but typically while sacrificing other parameters such as VSWR protection.

The overall performance of a hybrid coupled PA is limited by the hybrid couplers. The bandwidth of a hybrid coupler will limit the overall achievable bandwidth of the PA. A hybrid coupler with poor amplitude balance, which is the difference in amplitude of path 1 and path 2 after the ideal 3 dB split, can cause unequal amplitude splitting which can cause each amplifier to be driven more or less into compression than the other amplifier. Similarly, poor phase balance, the difference in phase at path 1 and path 2 compared to the ideal 90-degree phase shift, can cause poor phase combining and phase cancellation. This can reduce the overall output power if the signals do not combine in phase at the output port as well as minimizing the VSWR protection capability of a hybrid coupled PA. Furthermore, hybrid couplers are not lossless devices when realized, and therefore, slightly reduces the output power by the loss of the hybrid coupler. Hybrid coupler losses are minimal, typically less than 0.5 dB, but should still be carefully considered when implementing especially at high output power.

## Summary

When considering an amplifier device or module the designer and user must understand the tradeoffs between single ended amplifiers and hybrid coupled amplifiers. To meet the ongoing demand for PA solutions, the PA design must be carefully considered. These decisions are often not straightforward as requirements can begin to contest with each other. For instance, when size and VSWR protection are both requirements the designer or user may want to adopt a single ended amplifier to achieve size requirements. However, this would require the addition of an isolator or circulator to satisfy the requirement of VSWR protection. In these cases, a detailed analysis may be beneficial to determine if the inclusion of the isolator or circulator is smaller in size than the hybrid approach which inherently provides VSWR protection. Both amplifier techniques offer clear advantages for specific applications. The hybrid coupled amplifier technique is more quickly adaptable, especially for increased RF output power compared to single ended amplifiers. The hybrid approach can utilize existing COTS amplifiers and hybrid couplers to quickly add amplifiers in hybrid configuration. When small size or low cost are critical design constraints the single ended amplifier is often the best technical solution. The 90-degree hybrid coupled amplifier technique is important to consider, especially considering the many advantages it provides.

NuWaves Engineering is a premier supplier of RF and Microwave solutions for Department of Defense (DoD), government, and industrial customers. An RF engineering powerhouse, NuWaves offers a broad range of design and engineering services related to the development and sustainment



of key communications, telemetry and electronic warfare systems, as well as a complete line of commercially available RF products. NuWaves' products include wideband frequency converters, high-efficiency and miniature solid-state power amplifiers and bidirectional amplifiers, high intercept low noise amplifiers and miniature RF filters. NuWaves Engineering...Trusted RF Solutions™.

Contact Justin Wells, RF Design Engineer, at (513) 360-0800, [justin.wells@nuwaves.com](mailto:justin.wells@nuwaves.com), or visit [www.nuwaves.com](http://www.nuwaves.com) for more information.