

USER MANUAL

NUPOWER™ C30R01

C-BAND POWER AMPLIFIER

PART NUMBER:
NW-PA-C-30-R01



NuWaves RF Solutions
132 Edison Drive
Middletown, Ohio 45044
PH: 513-360-0800
FAX: 513-539-8782
www.nuwaves.com
sales@nuwaves.com

1 NUPOWER™ PRODUCT LINE OVERVIEW

The NuPower family of solid-state RF power amplifier (PA) modules is designed to meet the demanding needs of the Aerospace & Defense, Industrial, and Commercial markets. Based on the latest gallium nitride (GaN) technology, NuPower's power efficiency and miniature form factor make it ideal for size, weight, and power-constrained broadband RF telemetry and tactical communications systems.

1.1 NUPOWER™ PRODUCT LINE HIGHLIGHTS

- High Performance: Unique combination of broadband coverage, miniature form factors, and high efficiency.
- Enclosures: The NuPower family of power amplifiers is housed in a silver nickel plated aluminum enclosure with mounting holes incorporated into the chassis.
- Completely Characterized: The NuPower family of solid-state power amplifiers has been completely characterized over temperature, voltage, and frequency. These high-performance modules offer significant value for the OEM user or the Systems Integrator.
- User Friendly: Over-Voltage protection and regulator thermal shutdown provide defenses against user interface issues.
- High Reliability: NuWaves' selection of conservatively rated components provides high reliability. Each NuPower is inspected to IPC-A-610 Class II quality standards. NuWaves' Quality Management System is AS9100:2016 Rev D and ISO 9001:2015 certified.
- Applications: Broadband RF Telemetry • RF Communication Systems • Electronic Warfare • Unmanned Aircraft Systems (UAS) • Unmanned Ground Vehicles (UGV) • Unmanned Surface Vehicles (USV) • Software Defined Radios • Test Labs
- Available Options:
 - Fan-cooled heat sink with 28V operated fan
 - Labeled interface cable with banana jack plugs

2 NUPOWER™ C30R01 PA OVERVIEW

The NuPower™ C30R01 PA is a highly efficient, solid state power amplifier that provides over 30 watts of RF power across 5030 - 5090 MHz.

Based on the latest gallium nitride (GaN) technology, NuPower L-Band power efficiency and <math>< 10\text{ in}^3</math> cubic inch form factor make it ideal for size, weight, and power-constrained broadband RF telemetry and tactical communication systems.

The NuPower™ C30R01 ruggedized chassis allows the system integrator to easily incorporate the unit into a platform operating in harsh environments with limited space, such as small Unmanned Aircraft Systems (UAS).

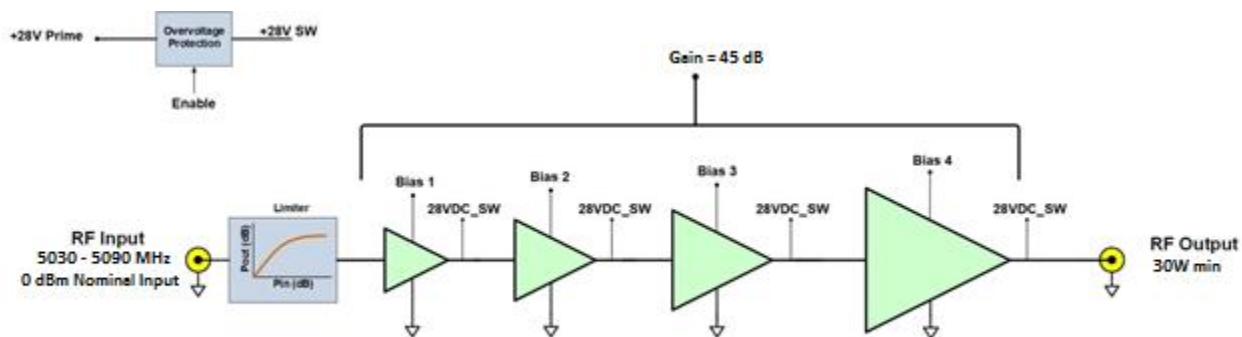

Figure 1: NuPower C30R01 Functional Diagram

2.1 NUPOWER C30R01 PA SPECIFICATIONS

The subsequent tables in this section outline the NuPower C30R01's performance specifications.

Table 1: NuPower C30R01 Electrical Specifications

Parameter	Specification
Frequency Range	5030 to 5090 MHz
RF Output Power	30 Watts (min)
Output Power @ 1 dB Compression	28 dBm @ 5030 MHz
	29 dBm @ 5060 MHz
	29 dBm @ 5090 MHz
RF Gain	45 dB
Input VSWR	2.3 (typ)
Output Mismatch (No Damage)	10:1
Nominal Input Drive Level	0 dBm
Maximum Input Drive Level (No damage)	+15 dBm
Harmonic	2 nd : ≤-70 dBc
	3 rd : ≤-70 dBc
Third Order Intercept Point (Two tone test at 1 MHz spacing, Pout = 20 dBm / tone)	40 dBm @ 5.03 GHz
Switching Speed	2 μs
Operating Voltage	+27 to +30 VDC
Operating Current	4.1 A @ +28 VDC (typ)
Module Efficiency	30%
Power Amplifier Enable	RF Enable Grounded
Impedance	50 Ω

Table 2: NuPower C30R01 Environmental Specifications

Operating Conditions	Specification
Operating Temperature	-40 to +55 °C (ambient) -40 to +85 °C (baseplate)
Storage Temperature	-55 to +85 °C

2.2 NUPOWER C30R01 PA MECHANICAL SPECIFICATIONS

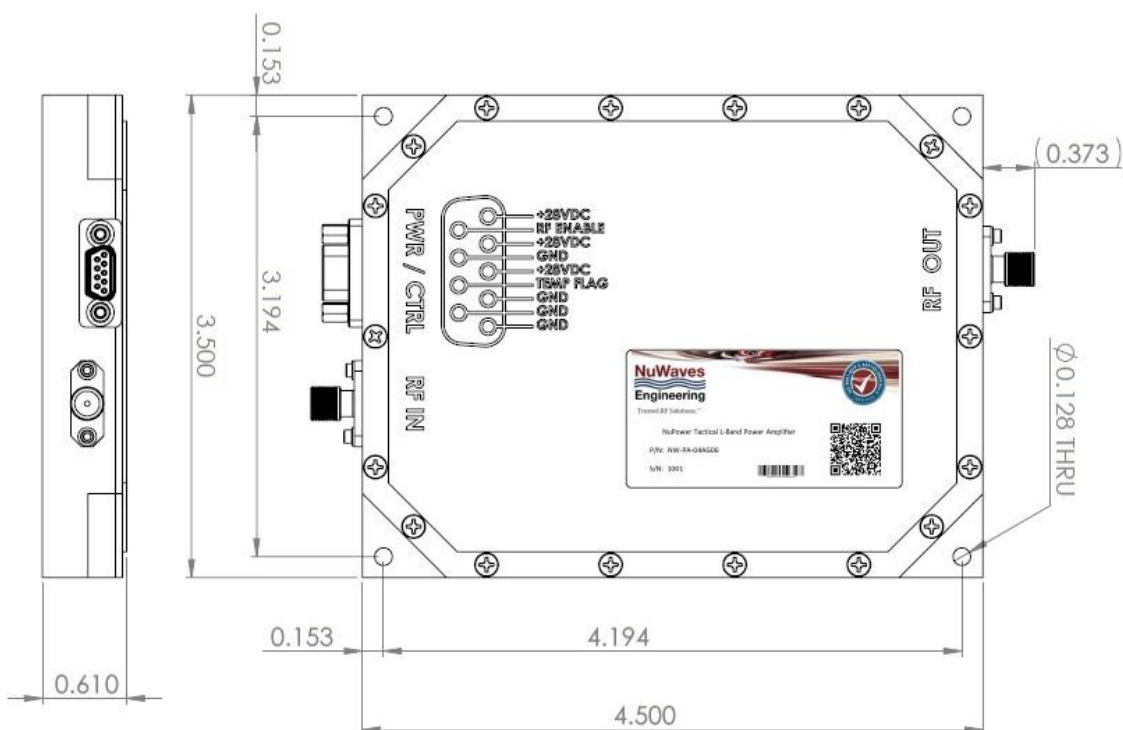

Figure 2: NuPower C30R01 Mechanical Outline

Table 3: NuPower C30R01 Mechanical Specifications

Parameter	Specification
RF Connectors	SMA (female)
Control / Power Interface Connector	9 Pin Micro-D (socket)
Dimensions (L x W x H)	4.5" x 3.5" x 0.61"
Weight	9 oz.

2.3 HEAT SINKING

The NuPower C30R01 is offered as a stand-alone module or with an accessory kit (P/N: NW-PA-ACC-KT03), which includes a 28 VDC fan-cooled heatsink and requisite power cable. [The kit also includes an upgraded module interface cable assembly, labeled and terminated with banana plugs.]

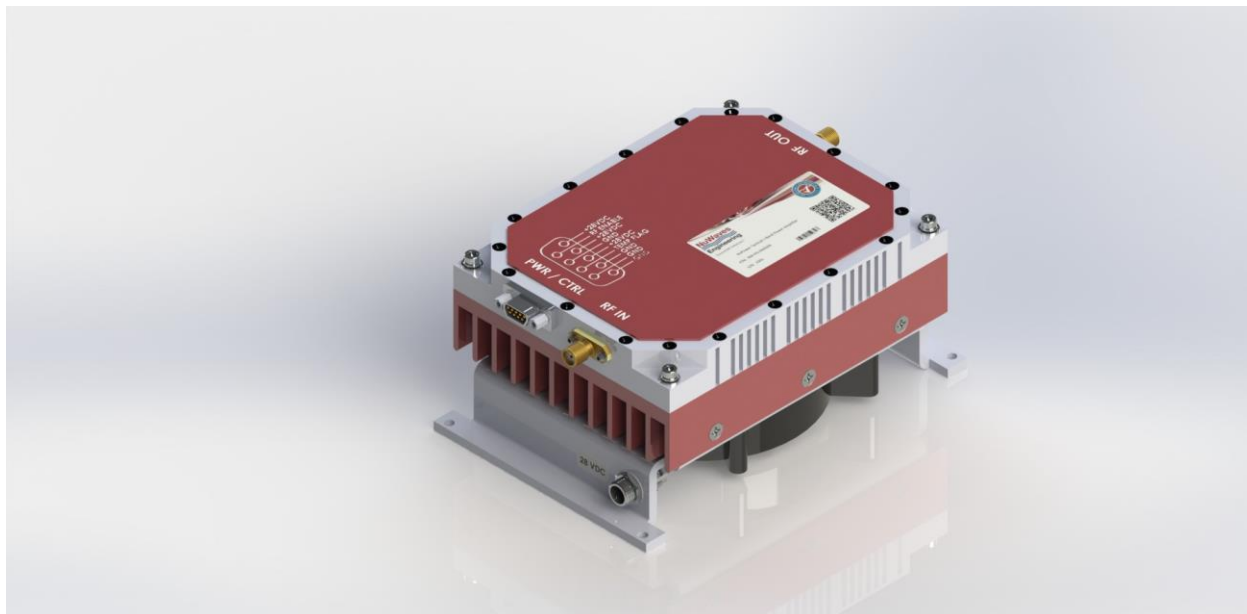

Figure 3: The NuPower PA Kit offers “out-of-the-box” operation for the user. The 28 VDC fan-cooled heatsink is shown with the NuPower C30R01 mounted.



Caution: The use of external heat-sinking is required especially for those applications requiring high duty cycle operation (e.g. continuous wave) or for extended on-time testing. Operation without a proper heat sink under these conditions will cause permanent damage to the product and will void the product warranty.

The max operating temperature is 85° C (baseplate).

3 SETUP AND OPERATION

This section provides specific details for proper operation of the NuPower C30R01 module. Following these guidelines will prevent damage to the power amplifier or external equipment.

3.1 POWER SUPPLY REQUIREMENTS

To operate the NuPower C30R01, ensure that the power supply has adequate overhead to source the current demand of the RF power amplifier. The power supply source must provide a typical voltage of +28 VDC with greater than 6 amps capability.

3.2 CONNECTING A PROPER LOAD TO THE ANTENNA TERMINAL

To prevent damage to the PA, the antenna terminal must be terminated into a 50 Ω load. Examples of a proper load include:

- Directly connecting to an antenna specified for the frequency range (5030 MHz to 5090 MHz). Connecting to an inappropriate antenna may result in damage to the PA module.
- Connecting to a proper antenna through a 50 Ω transmission line or coaxial cable. Avoid using damaged cables or corroded connectors while attaching the unit to an antenna.
- Terminating the antenna terminal into a 50 Ω power attenuator with minimum 20 dB attenuation.
- Connecting to a load capable of dissipating the RF power from the PA module. Loads capable of handling 50 Watts (min) are recommended.

3.3 POWERING-UP THE NUPOWER C30R01

The NuPower C30R01 must be terminated to a proper load before power is applied. Refer to Section 3.2 for the specifications of the proper load. After the PA is properly terminated, the interface cable can be connected to the unit and power can be applied. The PA is now ready for operation.

3.4 TRANSMIT TURN-ON TIME



Caution: Do not apply transmit data until the PA module is at full power. This will prevent loss of data at the beginning of a message.

The NuPower C30R01 is at full power approximately 1 μ S after the RF Enable line goes low (ground). Therefore, transmit data can be applied to the input after 1 μ S without loss of data.

3.5 RF OUTPUT POWER VS. SUPPLY VOLTAGE

The NuPower C30R01 was designed for +28 VDC operation.

4 HARDWARE INTERFACE

- The RF Input connector is SMA (female).
- The RF Output connector is SMA (female).
- The pin-out definitions for the 9 pin Micro-D socket connector are provided in Table 4. In a typical installation, the PA module is mated to a host controller board via a cable harness.



The RF Out SMA connector is the antenna connection. This connection should always be loaded into 50 Ω , otherwise the PA could be damaged.

4.1 INTERFACE CABLE HARNESS

The cable harness that connects the host controller to the 9 pin Micro-D connector of the NuPower C30R01 is made up of 9 wires.

Table 4: NuPower C30R01 Interface Pin-Out Definitions

Pin No.	Pin Name	I/O	Description
3, 4, 5	V Supply	I	Primary Power (+28 VDC)
1, 2, 6, 8	GND	I	Signal and Power Ground
7	Temp Flag	0	Over-temp Indicator 0V = temperature fault +5V = no fault
9	RF Enable	I	Transmit Control 0V or GND = RF On +5V or NC = RF Off

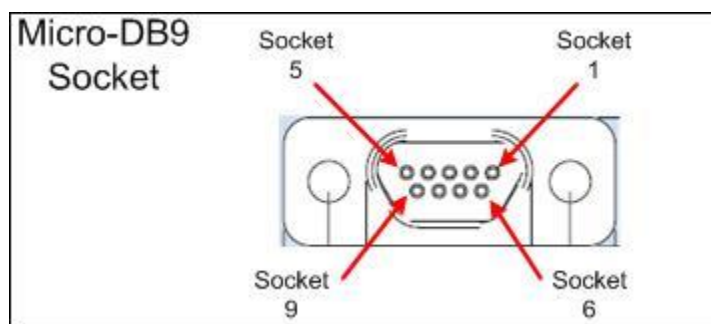

Figure 4: Micro-D Socket Locations

4.2 DC POWER

The nominal supply voltage for the NuPower C30R01 is +28 VDC; The acceptable supply voltage range is +27 to +30 VDC.

4.3 GROUND

The signal and power grounds are tied together in the PA module.

4.4 RF ENABLE

This signal is the logic control input that designates whether the unit is in transmit or standby mode. The RF Enable line is pulled high internally placing the PA module in *standby* mode. If the pin is left floating (i.e. not connected), the unit will default to *standby* mode.

Grounding the pin (i.e. a voltage below +0.2 VDC) places the unit in *transmit* mode. The user can either connect the RF Enable line to pins, 1, 2, 6 & 8 on the CTRL/PWR interface connector, or an open drain logic line capable of sinking 500 μ A to place the unit in *transmit* mode.

4.5 TEMP FLAG

This signal is an output to indicate an over-temperature condition in the NuPower C30R01. A logic high (+5 VDC) indicates normal operation, while a logic low (0 VDC) indicates an over-temperature condition. The NuPower C30R01 incorporates internal logic circuitry that turns off the DC bias to the RF transistors.



Caution: The amplifier should be shut down and allowed to cool off when the over-temperature flag is set low to avoid damage to the module.

5 PRODUCT DISPOSAL – END-OF-LIFE

Safety is a guiding principle of NuWaves RF Solutions. We ensure safe production and operation of our products, as well as end-of-life disposal. Improper disposal can adversely affect the environment, wildlife and human health. Please follow these guidelines when disposing of a NuWaves product:

- Do not remove the cover or any hardware
- Do not remove components from the circuit card assembly
- Do not incinerate
- Do not crush or shred
- Do not dispose of as unsorted municipal waste
- Do not export e-waste outside of the original destination country for recycling
- Utilize an e-Steward or ISO14001 certified e-waste recycler
- Consider export controls during recycler selection
- If a NuWaves product is incorporated into a larger system or sub-system, ensure that these guidelines are followed at system end-of-life

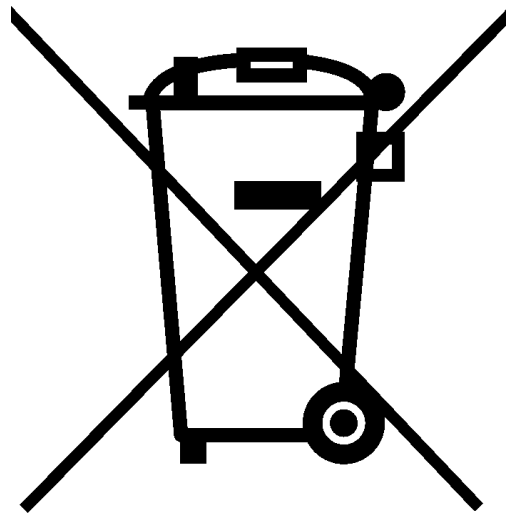

6 GETTING HELP - APPLICATIONS ENGINEERING

NuWaves RF Solutions offers technical support for basic configuration help and troubleshooting, Monday through Friday, 8 a.m. to 5 p.m. Eastern Time.

Technical Assistance, Application Engineering and Sales:

Phone: (513) 360-0800

Email: support@nuwaves.com

NuWaves Home Page: <https://www.nuwaves.com/>

Product Warranty:

https://nuwaves.com/wp-content/uploads/NuWaves_Warranty_Repair-1.pdf

6.1 GENERAL INFORMATION

Copyright © 2006 – 2019 NuWaves Ltd. All rights reserved. The information contained in this user manual is copyright protected. NuWaves reserves the right to make periodic modifications and product improvements to the NuPower product line and the associated documentation.