

USER MANUAL

VEGAS-S

DATA DIODE

PART NUMBER:
NW-1553-DD-VS01



NuWaves RF Solutions
132 Edison Drive
Middletown, Ohio 45044
Tel: 513-360-0800
www.nuwaves.com
sales@nuwaves.com

1 VEGAS-S OVERVIEW

The Vegas-S data diode provides security when accessing MIL-STD-1553 data buses. Offered in a ruggedized chassis, the module is ready for both lab and in-flight use. Acting as a physical firewall between the MIL-STD-1553 avionics bus and LRUs, this controlled data flow offers true risk mitigation to the aircraft’s avionics bus. Serving not only the data diode function, Vegas-S users also benefit from the module’s ability to recondition signals on the data bus, thus protecting the data against signal transients, while also benefiting from increased signal range (up to an additional 200ft of MIL-STD-1553 cabling).

To assist users of the Vegas-S product, interface cable part number CYB-CBL-02-F is available as a purchase option.

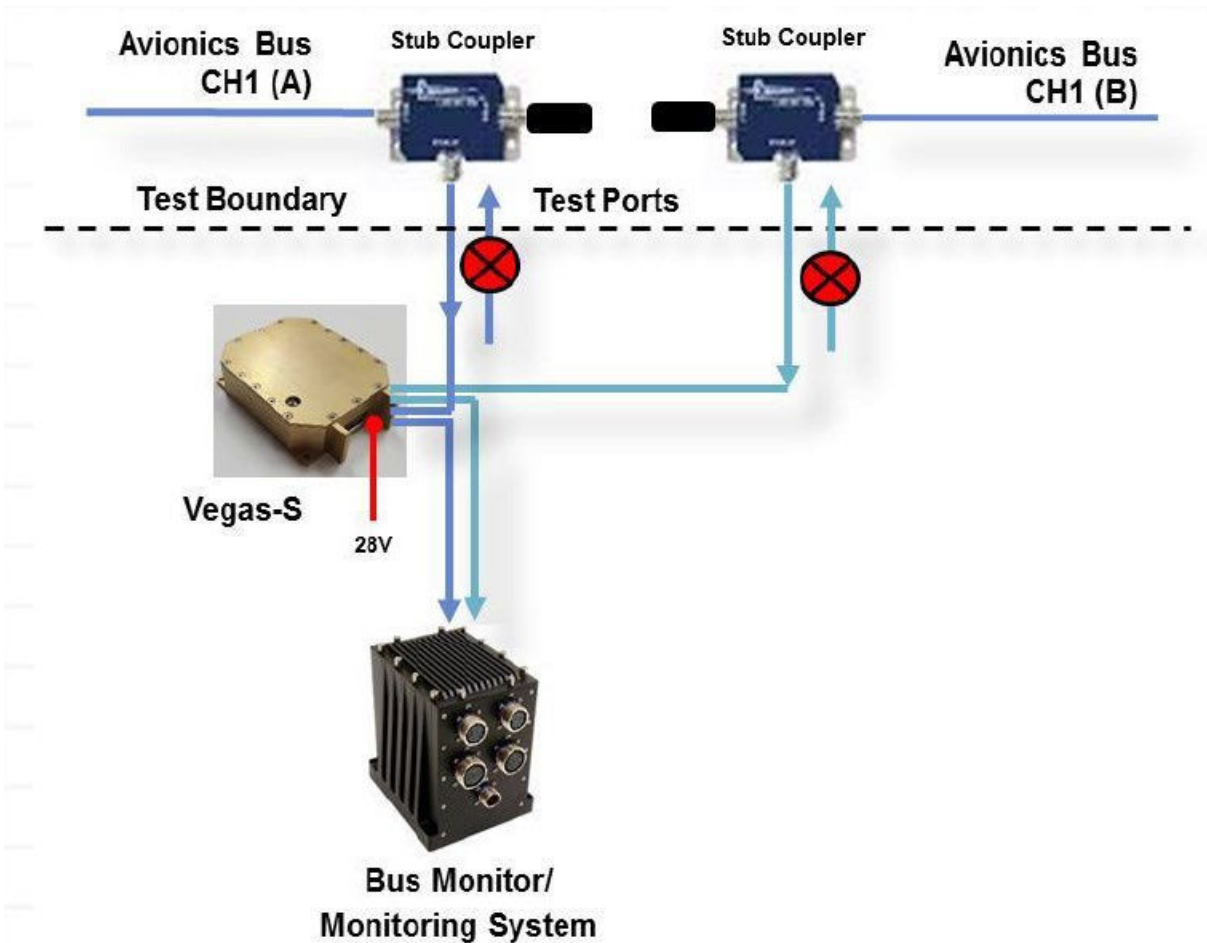

Figure 1: Vegas-S Typical System Implementation

VEGAS-S PERFORMANCE HIGHLIGHTS

Performance highlights of the Vegas-S module are outlined in Table 1 below.

Design Characteristic	Benefit
Current	40 mA
Input Voltage	28 VDC
Design Simplicity	No loadable firmware or software, single chip solution
Latency	Low input to output latency (200 ns)
Ruggedized Design	Tested to an array of MIL-STD-810G, MIL-STD-704F, and MIL-STD-461G tests
Transient Signal Protection	Protects against voltage transients while also reconditioning data signals
Extended Range	Offers extended range of up to 200 ft of MIL-STD-1553 cabling
Data Diode	Protects avionics bus from malicious attack through physical hardware

Table 1: Vegas-S Performance Highlights

2 VEGAS-S FUNCTIONAL DESCRIPTION

The Vegas-S physically hardwires MIL-STD-1553 transceivers to maintain one-way data flow. LRUs can therefore only receive commands and messages, and any attempt at a response is blocked from entering the rest of the data bus system. All erroneous or malicious messages originating in a compromised LRU are halted at the Vegas-S module.

No software or firmware is present in the Vegas-S module.

The inset Number 2 screw in the lid conceals a power indicator LED. To confirm proper power input to the module, remove inset screw. An illuminated LED (color blue) signifies power supplied to the module is appropriate.

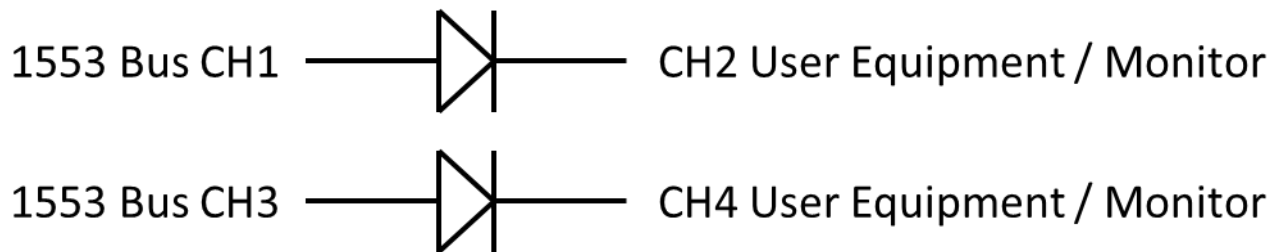

Figure 2: Data Connections

INTERFACE DEFINITIONS

The connector pin-out definitions for the module’s connector are provided in Table 2. In a typical installation, the Vegas-S module is mated to a MIL-STD-1553 data bus and power supply via an interface cable. Figure 3 below shows the connector pin numbers, as viewed from the front of the module.

Pin Number	Pin Name	Description	I/O
1, 3, 6, 8	GND	DC Ground.	I
2	CH 3 Low	MIL-STD-1553 Low Channel 3	I
4	CH 3 High	MIL-STD-1553 High Channel 3	I
5	CH 2 Low	MIL-STD-1553 Low Channel 2	O
7	CH 2 High	MIL-STD-1553 High Channel 2	O
9	CH 4 Low	MIL-STD-1553 Low Channel 4	O
10	CH 4 High	MIL-STD-1553 High Channel 4	O
11, 12	28 VDC Return	DC Supply Voltage, Return	O
13	+28 VDC	DC Supply Voltage, +28 Volts.	I
14	CH 1 Low	MIL-STD-1553 Low Channel 1	I
15	CH 1 High	MIL-STD-1553 High Channel 1	I

Table 2: Vegas-S Pin-Out Definitions

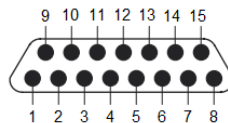

Figure 3: Connector Pin-Out (as viewed from the front of the module)

INTERFACE CABLE (PURCHASE OPTION)

The 36" shielded interface cable is comprised of a 15 pin micro-D connector on one end, and four MIL-STD-1553 connectors and one power connector on the opposite end. This cable provides input power to the Vegas-S module and allows interfacing with the MIL-STD-1553 data bus.

Channel 1 on the interface cable is a MIL-STD-1553 input, and Channel 2 is the corresponding output. Channel 3 is an additional input, with Channel 4 the corresponding output. On the power connector, the pin labeled "30A 28VDC" is the positive pin. The pin labeled "NEMA FSL1" is the ground pin. Figure 4 shows NuWaves part number CYB-CBL-02-F.

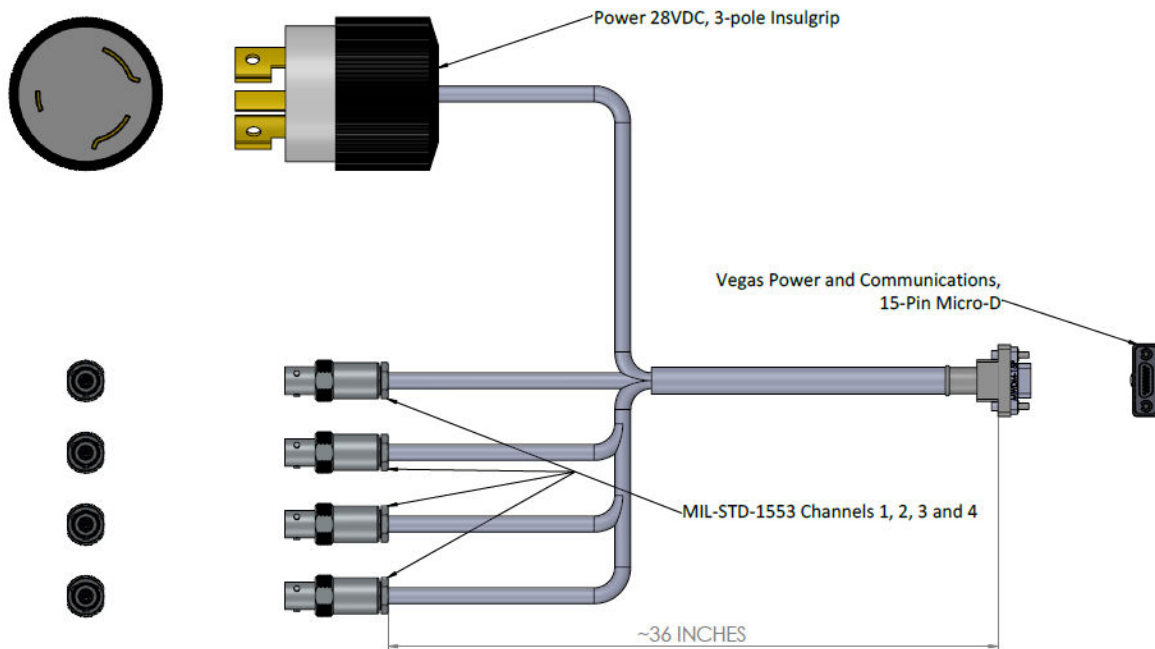

Figure 4: CYB-CBL-02-F Vegas-S Interface Cable

3 MECHANICAL

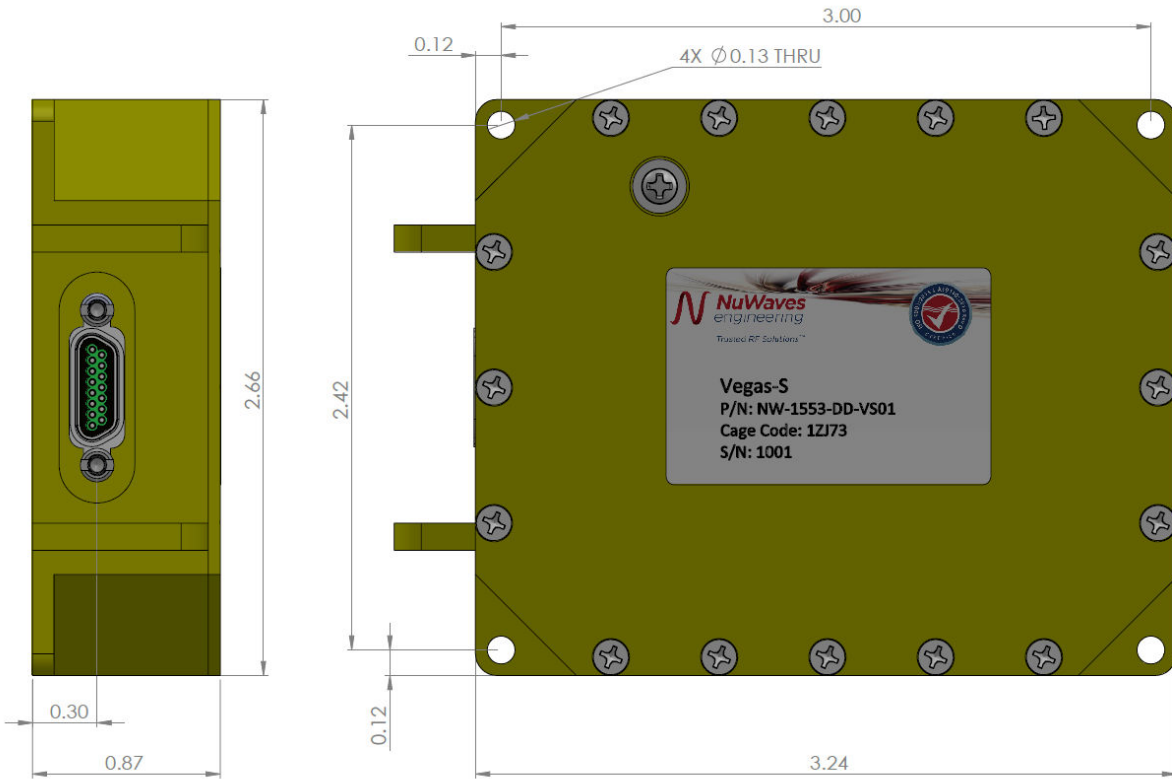

Figure 5: Vegas-S Mechanical Outline

Parameter	Specification
Interface Connector	15 Pin Micro-D
Dimensions (LxWxH)	3.24" x 2.66" x 0.87"
Weight	0.5 lbs

Table 3: Vegas-S Mechanical Specifications

4 PRODUCT DISPOSAL – END-OF-LIFE

Safety is a guiding principle of NuWaves RF Solutions. We ensure safe production and operation of our products, as well as end-of-life disposal. Improper disposal can adversely affect the environment, wildlife and human health. Please follow these guidelines when disposing of a NuWaves product:

- Do not remove the cover or any hardware
- Do not remove components from the circuit card assembly
- Do not incinerate
- Do not crush or shred
- Do not dispose of as unsorted municipal waste
- Do not export e-waste outside of the original destination country for recycling
- Utilize an e-Steward or ISO14001 certified e-waste recycler
- Consider export controls during recycler selection
- If a NuWaves product is incorporated into a larger system or sub-system, ensure that these guidelines are followed at system end-of-life

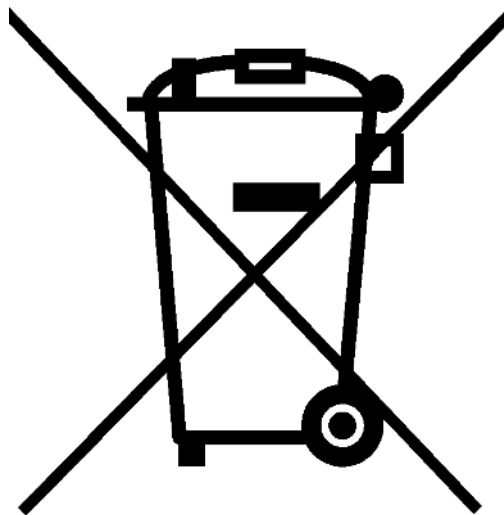

5 GETTING HELP - APPLICATIONS ENGINEERING

NuWaves RF Solutions offers technical support for basic configuration help and troubleshooting, Monday through Friday, 8 a.m. to 5 p.m. Eastern Time.

Technical Assistance and Application Engineering:

Email: sales@nuwaves.com

Phone: (513) 360 - 0800

NuWaves Home Page: <https://www.nuwaves.com/>

Product Warranty:

https://nuwaves.com//srv/htdocs/wp-content/uploads/NuWaves_Warranty_Repair-1.pdf

GENERAL INFORMATION

Copyright © 2006 – 2024 NuWaves Ltd. All rights reserved. The information contained in this user manual is copyright protected. NuWaves reserves the right to make periodic modifications and product improvements to the Vegas-S product line and the associated documentation.