

# NuWaves

## RF Solutions

### NuPower™ LS-20-C01-S01 L- & S-Band Solid State Power Amplifier

20 Watt CW  
1.0 GHz - 2.5 GHz



P/N: NW-PA-LS-20-C01-S01

**The NuPower™ LS-20-C01-S01 is a small, highly efficient solid state power amplifier that provides 20 watts (typ) of RF power to boost performance of data links and transmitters.**

Based on the latest gallium nitride (GaN) technology, NuPower's 30% - 50% power efficiency and 3.9 in<sup>3</sup> form factor make it ideal for size, weight, and power-constrained broadband RF telemetry and tactical communication systems.

The NuPower LS-20-C01-S01 power amplifier accepts a nominal 0 dBm RF input and provides over 40 dB of gain from 1.0 GHz to 2.5 GHz. The NuPower LS-20-C01-S01 module comes with an optional NW-PA-ACC-CB09MA interface cable, for ease of integration.

NuPower PAs feature over-voltage and reverse-voltage protection and can operate over a wide temperature range of -40 °C to +60 °C.

**Extend your operational communication range with NuPower™ amplifiers from NuWaves RF Solutions.**

#### Features

- 20 Watts RF Output Power
- 1.0 GHz to 2.5 GHz
- Miniature Package (3.00" x 2.00" x 0.65")
- High-Efficiency GaN Technology
- 0 dBm Nominal RF Input
- Reverse-Voltage Protection
- Logic On/Off Control

#### Benefits

- Extended Range
- Improved Link Margin
- Reduced load on DC power budget due to high efficiency operation
- Requires less volume on space-constrained platforms

#### Applications

- Unmanned Aircraft Systems (UAS), Group 2 & 3
- Unmanned Ground Vehicles (UGV)
- Broadband RF Telemetry
- RF Communication Systems
- Software Defined Radios

# NuPower™ LS-20-C01-S01 Power Amplifier

## Specifications

### Absolute Maximums

Parameter	Rating	Unit
Max Device Voltage	32	V
Max Device Current	2.8	A
Max RF Input Power, $Z_L = 50 \Omega$	10	dBm
Max Operating Temperature (ambient)	60	°C
Max Operating Temperature (baseplate)	85	°C
Max Storage Temperature	85	°C

Export Classification
EAR99

### Electrical Specifications @ 28VDC, 25 °C, $Z_S=Z_L=50 \Omega$

Parameter	Symbol	Min	Typ	Max	Unit	Condition
Operating Frequency	BW	1000		2500	MHz	
RF Output Power	$P_{SAT}$	15	22	30	W	$P_{in} = 0 \text{ dBm}$
Output Power @ 1dB Compression	P1dB		27		dBm	1.0 GHz
			30			1.5 GHz
			33			2.0 GHz
			33			2.5 GHz
Small Signal Gain	G		52		dB	1.0 GHz, @ -30 dBm input
			50			1.5 GHz, @ -30 dBm input
			49			2.0 GHz, @ -30 dBm input
			49			2.5 GHz, @ -30 dBm input
Small Signal Gain Flatness	$\Delta G$		$\pm 2$		dB	$P_{in} = -30 \text{ dBm}$
Power Gain Flatness			$\pm 1$		dB	$P_{in} = 0 \text{ dBm}$
Input VSWR	VSWR	1.1:1	1.8:1	5:1		
Nominal Input Drive Level	$P_{IN}$		0		dBm	
Operating Voltage	VDC	11	28	32	V	
Quiescent Current	$I_{DQ}$		0.610		A	
Operating Current	$I_{DD}$	1.5	2.1	2.8	A	$P_{in} = 0 \text{ dBm}$
Module Efficiency		29	41	51	%	$P_{in} = 0 \text{ dBm}$
Switching Speed	$T_{XON/OFF}$			2	$\mu\text{s}$	10% to 90%
Third Order Intercept Point (Two tone test at 1 MHz spacing, $P_{out} = 20 \text{ dBm} / \text{tone}$ )	OIP3		42		dBm	1.0 GHz
			42			1.5 GHz
			44			2.0 GHz
			45			2.5 GHz
Harmonics	2nd	-20	-28	-8	dBc	
	3rd	-30	-22	-14		
Output Mismatch w/o Damage				10:1		

# NuPower™ LS-20-C01-S01 Power Amplifier

## Specifications (cont.)

### Mechanical Specifications

Parameter	Value	Unit	Limits
Dimensions	3.0 x 2.0 x 0.65	in	Max
Weight	3	oz	Max
RF Connectors, Input/Output	SMA Female		
Interface Connector	Micro-D, 9-pin Socket		
Cooling	Adequate Heatsink Required		

### Environmental Specifications

Parameter	Symbol	Min	Typ	Max	Unit
Operating Temperature (ambient)	$T_A$	-40		+60	°C
Operating Temperature (baseplate)	$T_C$	-40		+85	°C
Storage Temperature	$T_{STG}$	-55		+85	°C
Relative Humidity (non-condensing)	RH			95	%
Altitude MIL-STD-810F - Method 500.4	ALT			30,000	ft
Vibration / Shock Profile (Random profile in x,y, z axis, as per Figure for 15 minute duration in each axis)					

## Performance Plots

Test Conditions: +28 VDC, +25 °C,  $Z_S=Z_L=50 \Omega$

Power Input vs. Power Output

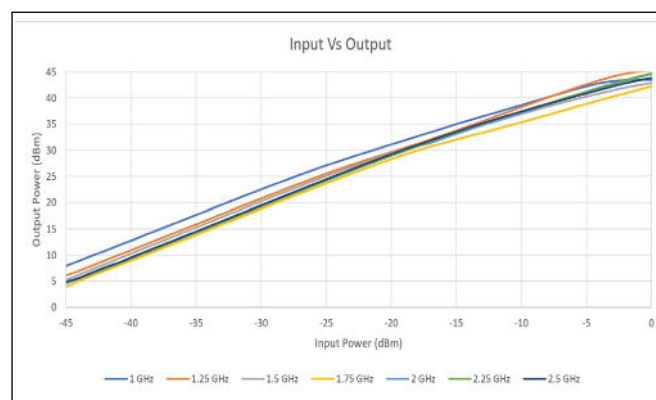

Gain vs. Input Power

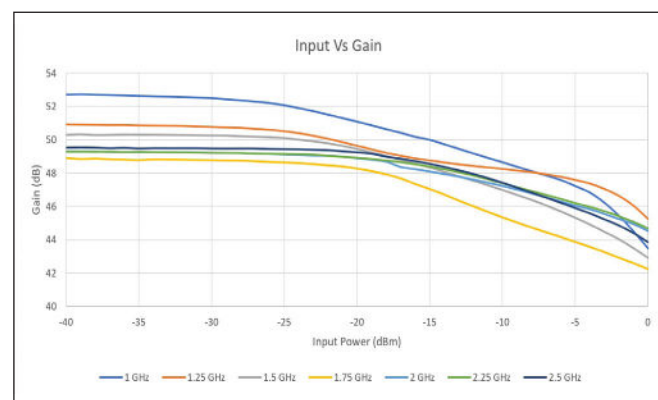

# NuPower™ LS-20-C01-S01 Power Amplifier

## Performance Plots (cont.)

RF Power @ 0 dBm Input

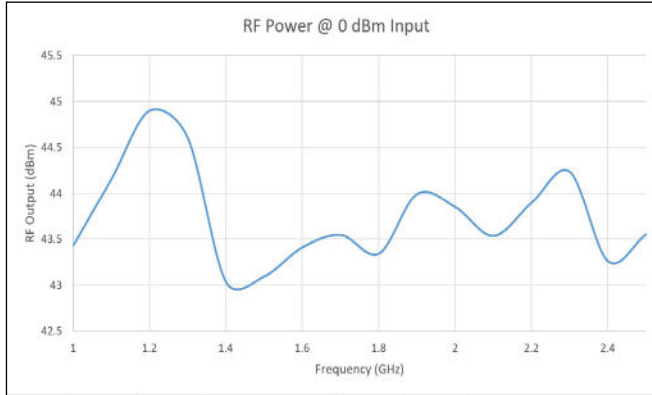

Gain vs. Input Power

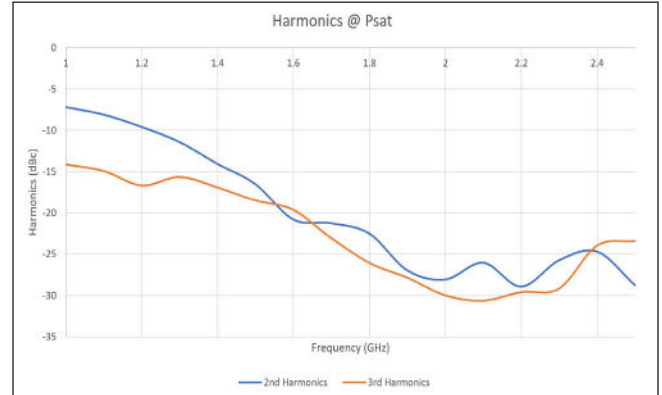

P1dB & P3dB

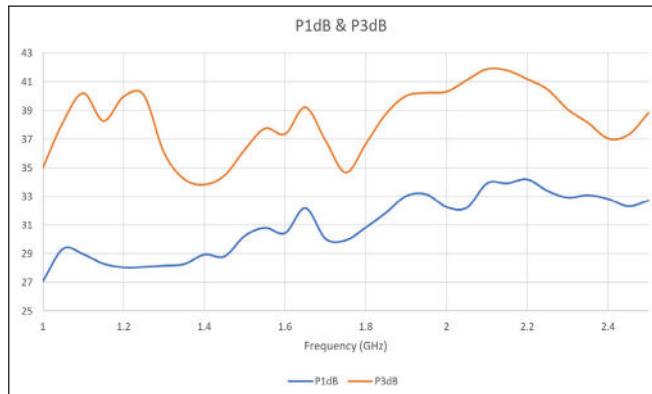

OIP3

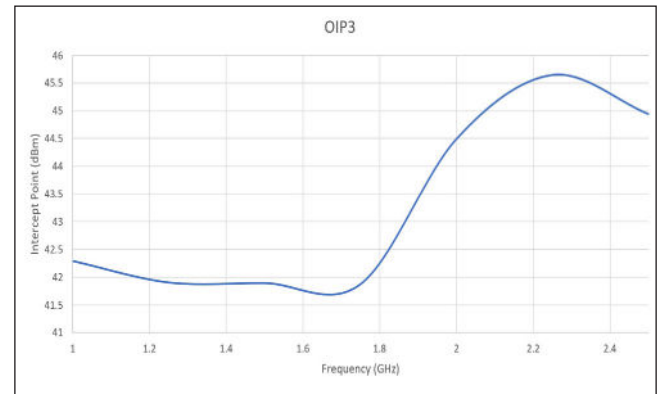

Gain - Stepped Input

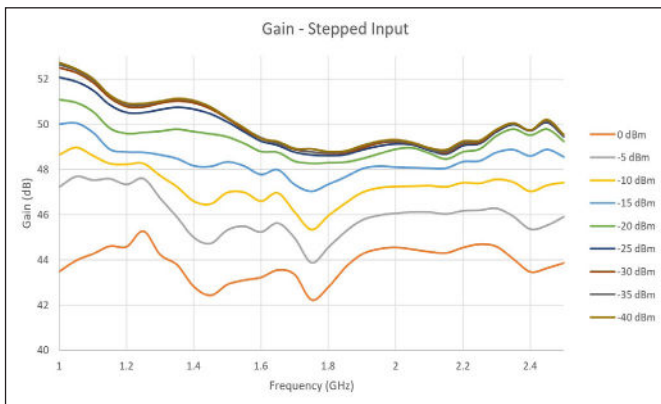

Small Signal Gain (-30 dBm Input)

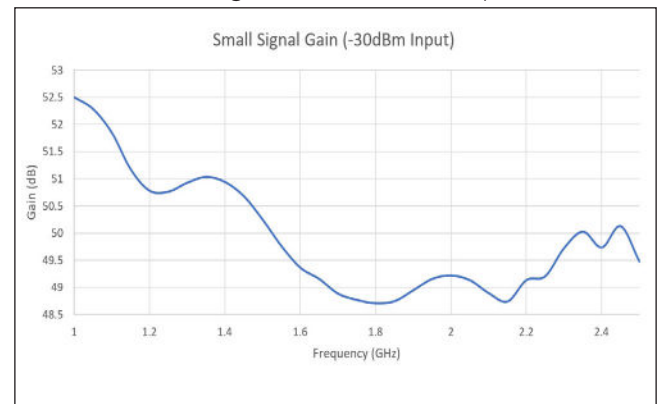

# NuPower™ LS-20-C01-S01 Power Amplifier

## Performance Plots (cont.)

Current Consumptions +28VDC @ 0 dBm Input

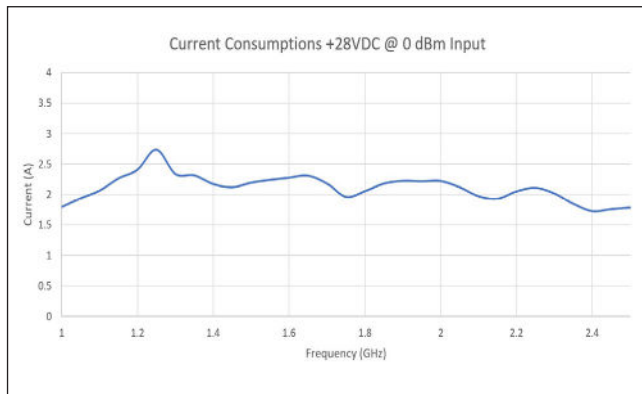

Power Added Efficiency @ 0 dBm Input

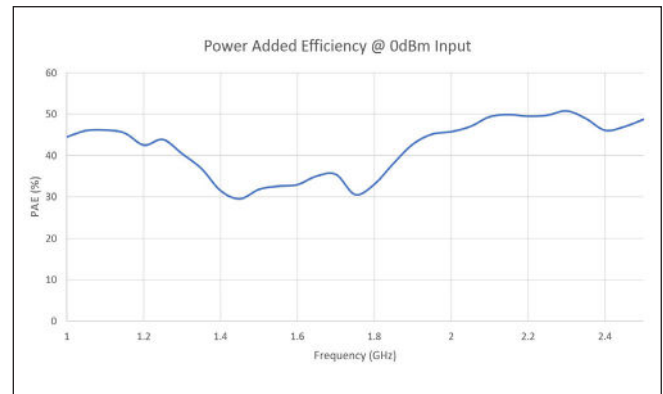

Input VSWR

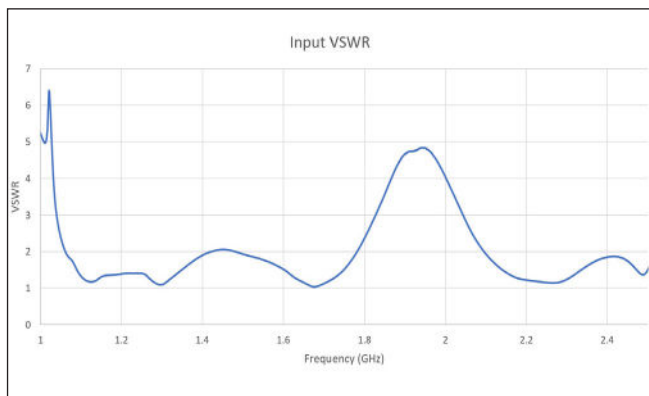

EVM vs. Input Power (16-QAM 2Msps)

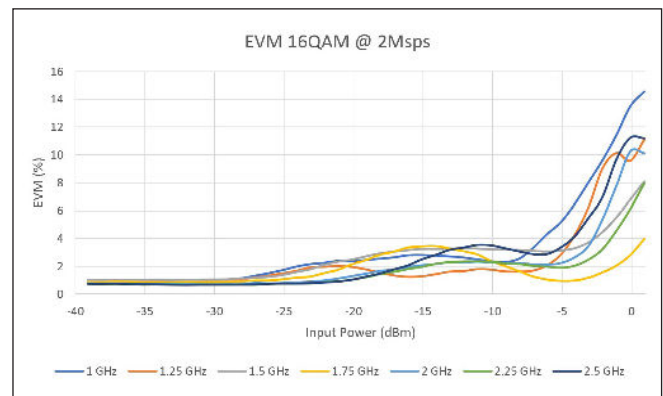

EVM vs. Output Power (16-QAM 2Msps)

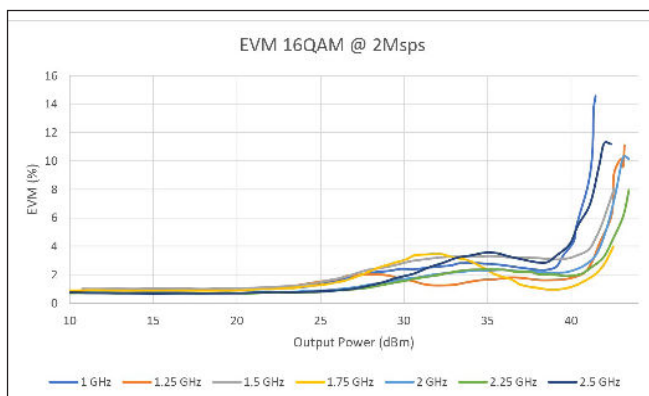

EVM vs. Input Power (32-QAM 2Msps)

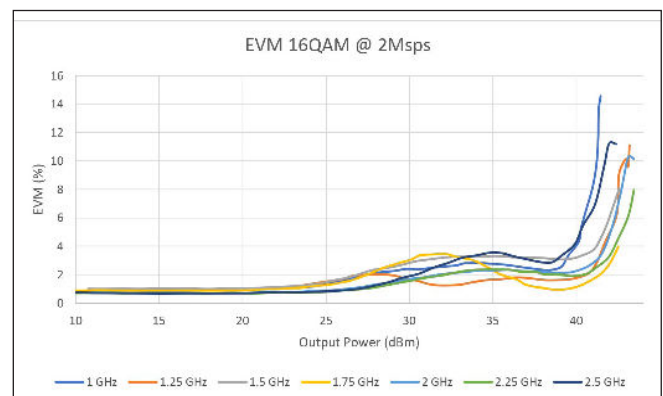

# NuPower™ LS-20-C01-S01 Power Amplifier

## Performance Plots (cont.)

EVM vs. Output Power (32-QAM 2Msps)

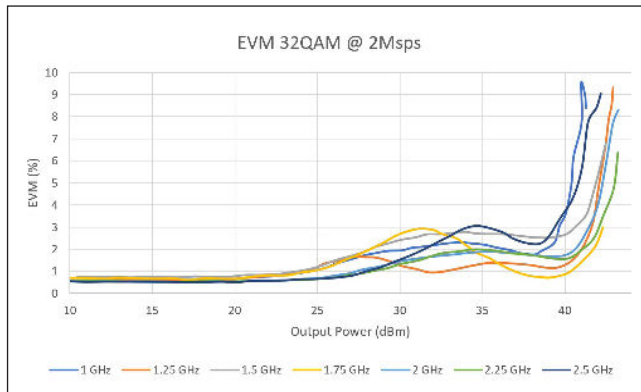

EVM vs. Input Power (64-QAM 2Msps)

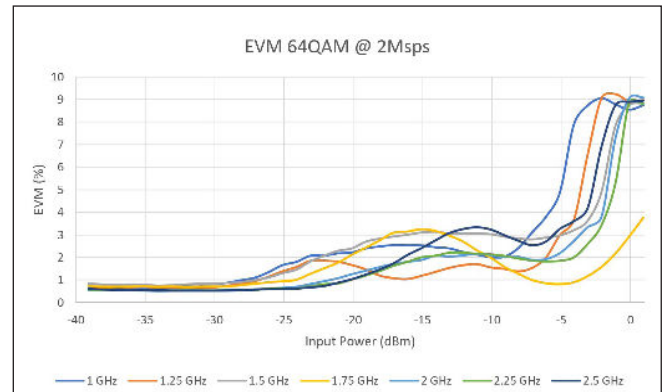

EVM vs. Output Power (64-QAM 2Msps)

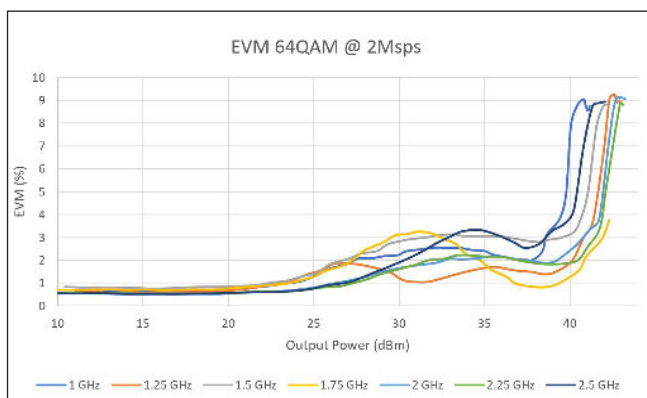

EVM vs. Input Power (QPSK @ 2 Msps)

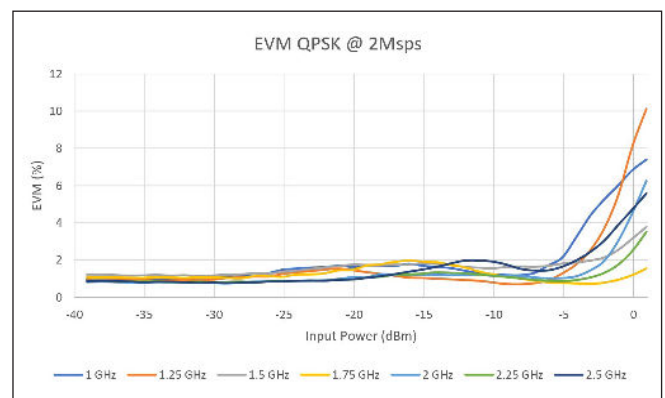

EVM vs. Output Power (QPSK @ 2 Msps)

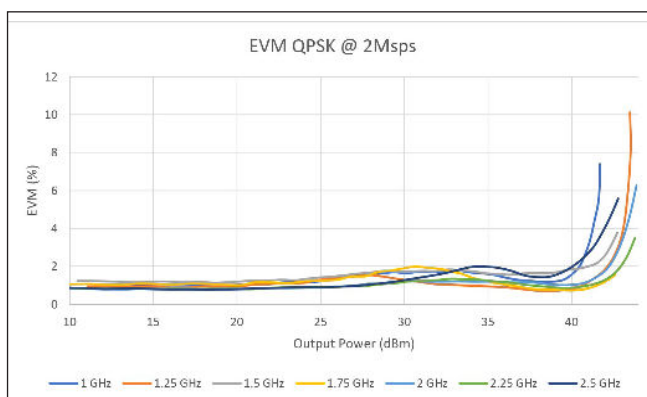

# NuPower™ LS-20-C01-S01 Power Amplifier

## Mechanical Outline

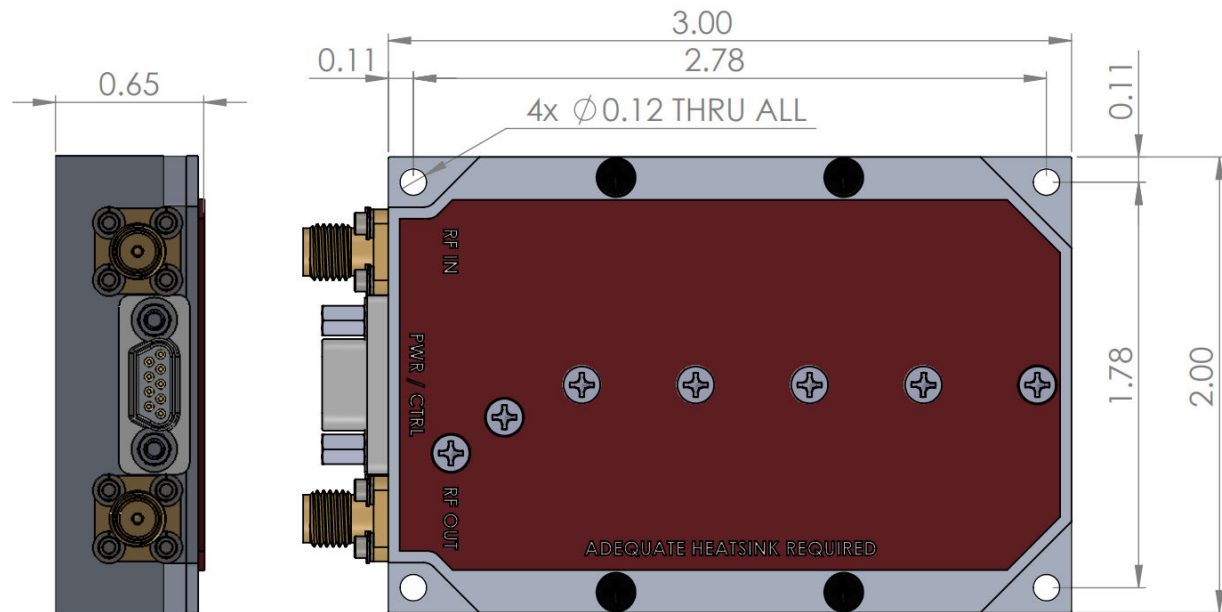

## Accessory Part Numbers - Sold Separately

Part Number	Description
NW-FL-05LPLE-2500-SFSF-M01	Harmonic Filter Module
NW-PA-ACC-CB09MA	Standard Interface Cable Assembly - Flying Leads
NW-PA-ACC-CT09MA	Upgraded Interface Cable Assembly - Banana Plug Termination
HTSK-01	Heatsink with Integrated Fan

## Pinout

Function	I/O	Pin
DC Power (+11 to +32 VDC)	I	1, 2
Ground	I	3, 4
RF Enable 0V or GND = RF ON +5V or NC = RF OFF	I	5
No Connect	-	6, 7, 9
Over Temperature Flag 0V = temperature fault +5V = no fault	0	8

For information on product disposal (end-of-life), please refer to this document:  
<https://nuwaves.com/wp-content/uploads/Product-Disposal-End-of-Life.pdf>

## Contact NuWaves



NuWaves RF Solutions  
 132 Edison Drive  
 Middletown, OH 45044

[www.nuwaves.com](http://www.nuwaves.com)  
[sales@nuwaves.com](mailto:sales@nuwaves.com)  
 513.360.0800

