

NuWaves

RF Solutions

NuPower™ L-10-C01-S01 L-Band Power Amplifier

Precision Output Power Control
18 Watt CW (typ)
1700 MHz - 1850 MHz

P/N: NW-PA-L-10-C01-S01



Contact sales@nuwaves.com for custom options

The NuWaves' NuPower™ L-10-C01-S01 is a smart, miniature solid state power amplifier (SSPA) that typically delivers 18 watts of RF power across the frequency range of 1700 to 1850 MHz, and features automatic gain with RF output power level adjustment.

The NuPower L-10-C01-S01 offers digital control through a simple RS-232 interface. Utilizing the onboard automatic gain control, the NuPower L-10-C01-S01 offers 16 discrete, user-programmable output settings, in 1 dB steps from the maximum RF output power level.

Based on the latest gallium nitride (GaN) technology, the NuPower L-10-C01-S01's 38 - 43% power efficiency and small 7.75 in³ form factor make it ideal for size, weight, and power-constrained RF telemetry and tactical communication systems. The NuPower L-10-C01-S01's rugged chassis allows the system integrator to easily incorporate the unit into a platform operating in harsh environments with limited space.

Extend your operational communication range with NuPower™ amplifiers from NuWaves RF Solutions.

Features

- 18 Watts (typ) RF Output Power
- 1700 to 1850 MHz
- Maintains Output Power over Input Power of 0 dBm to +10 dBm
- Small form Factor (2.125" x 5" x 0.73")
- High-Efficiency GaN Technology
- Single Power Supply
- Over-Voltage Protection
- Reverse-Voltage Protection

Benefits

- Extended Range
- Improved Link Margin
- Lessened load on DC power budget due to high efficiency operation
- Consumes less volume on space-constrained platforms
- Precision Power Control

Applications

- Unmanned Aircraft Systems (UAS), Group 2 through Group 5
- Air Launch Effect (ALE)
- Common Launch Tube (CLT)
- Counter UAS Detection & Mitigation
- MIMO/MANET Radio Range Extension
- SISO Radio Range Extension
- Test Labs

NuPower™ L-10-C01-S01 Power Amplifier

Specifications

Absolute Maximums

Parameter	Rating	Unit
Max Device Voltage	32	V
Max Device Current	3	A
Max RF Input Power, $Z_L = 50 \Omega$	12	dBm
Max Operating Temperature (ambient)	60	°C
Max Operating Temperature (baseplate)	85	°C
Max Storage Temperature	85	°C

Export Classification
EAR99

Electrical Specifications @ 28 VDC, 25 °C, $Z_S=Z_L=50 \Omega$, CW, 0 dBm Input Power, P_{max} , Unless otherwise stated

Parameter	Symbol	Min	Typ	Max	Unit	Condition
Operating Frequency	BW	1700		1850	MHz	
RF Output Power	P_{SAT}	10	18		W	1.70-1.85 GHz
Small Signal Gain	G		59		dB	$P_{in} = -40$ dBm
Small Signal Gain Flatness	ΔG		± 0.86		dB	$P_{in} = -40$ dBm; 1.70-1.85 GHz
Power Gain Flatness	ΔG		± 0.42		dB	
Input VSWR	VSWR		1.4:1			
Nominal Input Drive Level	P_{IN}		0		dBm	
Operating Voltage	VDC	22	28	32	V	
Quiescent (standby) Current	I_{DQ}		0.13		A	RF OFF (RF Enable Floating)
Quiescent (bias) Current	I_{DQ}		0.43		A	RF ON (RF Enable Low)
Operating Current	I_{DD}		1.57	3	A	
Module Efficiency			42		%	
Harmonics	2nd		-81		dBc	
	3rd		-85			
Output Mismatch (No Damage)				10:1	Ψ	No damage at all phase angles

Power Control @ 28 VDC, 25 °C, $Z_S=Z_L=50 \Omega$

Setting	Description	Typical Output Power	Typical Current
P_{max}	Maximum Output Power	42.62 dBm	1.57 A
$P_{max} - 1$	1 dB Backoff from P_{max}	41.48 dBm	1.35 A
$P_{max} - 2$	2 dB Backoff from P_{max}	40.64 dBm	1.23 A
$P_{max} - 3$	3 dB Backoff from P_{max}	39.66 dBm	1.10 A
$P_{max} - 4$	4 dB Backoff from P_{max}	38.70 dBm	1.00 A
$P_{max} - 5$	5 dB Backoff from P_{max}	37.66 dBm	0.90 A
$P_{max} - 6$	6 dB Backoff from P_{max}	36.60 dBm	0.81 A
$P_{max} - 7$	7 dB Backoff from P_{max}	35.67 dBm	0.74 A
$P_{max} - 8$	8 dB Backoff from P_{max}	34.60 dBm	0.68 A
$P_{max} - 9$	9 dB Backoff from P_{max}	33.62 dBm	0.63 A
$P_{max} - 10$	10 dB Backoff from P_{max}	32.62 dBm	0.58 A
$P_{max} - 11$	11 dB Backoff from P_{max}	31.72 dBm	0.55 A
$P_{max} - 12$	12 dB Backoff from P_{max}	30.65 dBm	0.52 A
$P_{max} - 13$	13 dB Backoff from P_{max}	29.61 dBm	0.49 A
$P_{max} - 14$	14 dB Backoff from P_{max}	28.69 dBm	0.46 A
P_{min}	15 dB Backoff from P_{max}	27.54 dBm	0.44 A

NuPower™ L-10-C01-S01 Power Amplifier

Specifications (cont.)

Mechanical Specifications

Parameter	Value	Unit	Limits
Dimensions	2.125 x 5.000 x 0.730	in	Max
Weight	8	oz	Max
RF Connectors, Input/Output	SMA Female		
Interface Connector	Micro-D, 9-Pin Socket		
Cooling	Adequate Heatsink Required		

Environmental Specifications

Parameter	Symbol	Min	Typ	Max	Unit
Operating Temperature (ambient)	T_A	-40		+60	°C
Operating Temperature (baseplate)	T_C	-40		+85	°C
Storage Temperature	T_{STG}	-55		+85	°C
Relative Humidity (non-condensing)	RH			95	%
Altitude MIL-STD-810F - Method 500.4	ALT			30,000	ft
Vibration / Shock Profile (Random profile in x,y, z axis, as per Figure for 15 minute duration in each axis)					

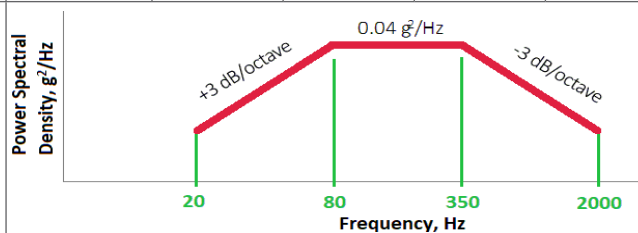

NuPower™ L-10-C01-S01 Power Amplifier

Performance Plots

Test Conditions: +28 VDC, +25 °C, $Z_s=Z_L=50 \Omega$, CW, Pmax, 0 dBm Input Power (unless otherwise specified)

Output Power [Pin: 0 to +10 dBm]

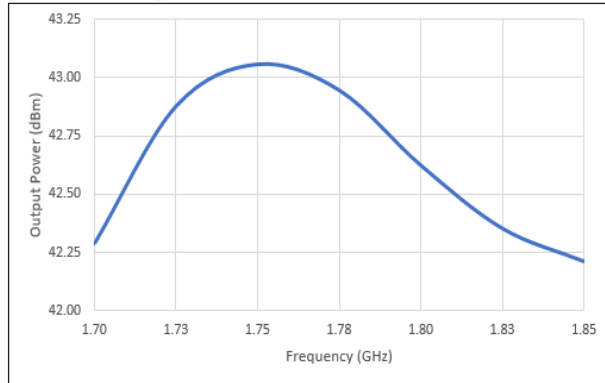

Output Power - Stepped Input Power

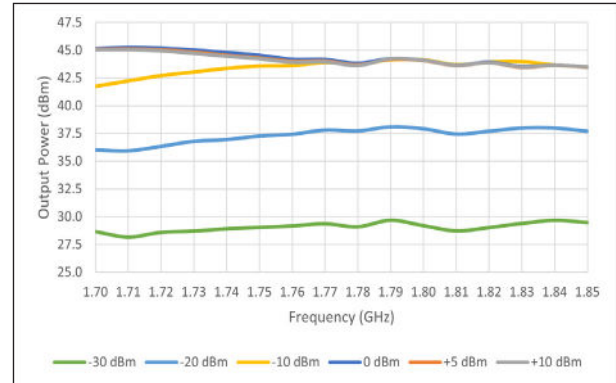

Output Power - Power Backoff

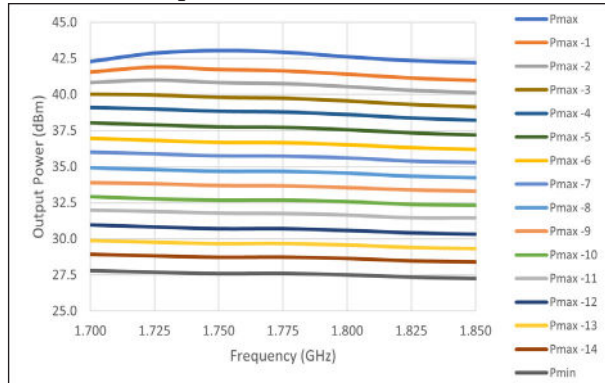

Output Power vs. Temperature

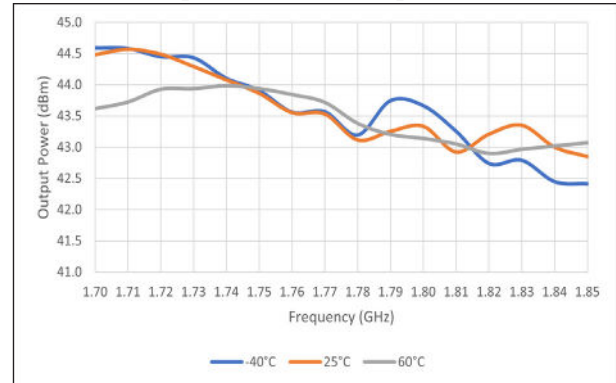

Output Power vs. Input Power

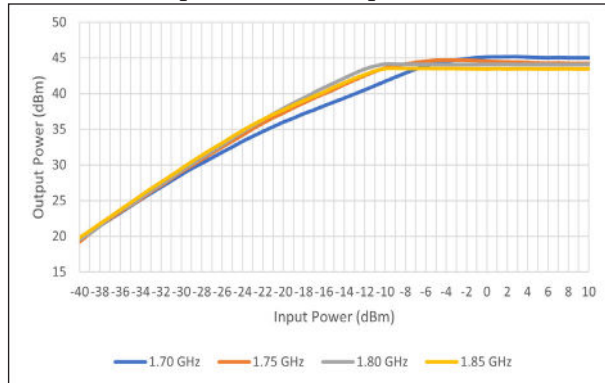

Output Power vs. Input Voltage

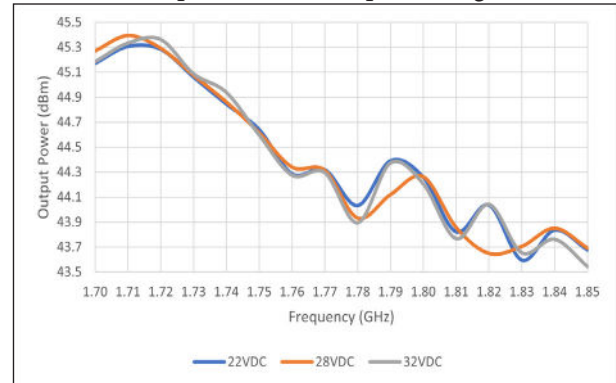

Small Signal Gain

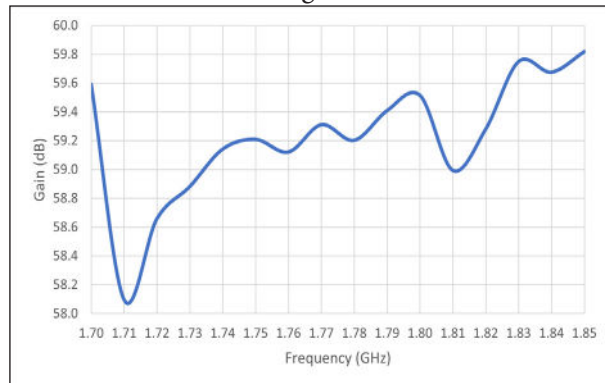

Efficiency

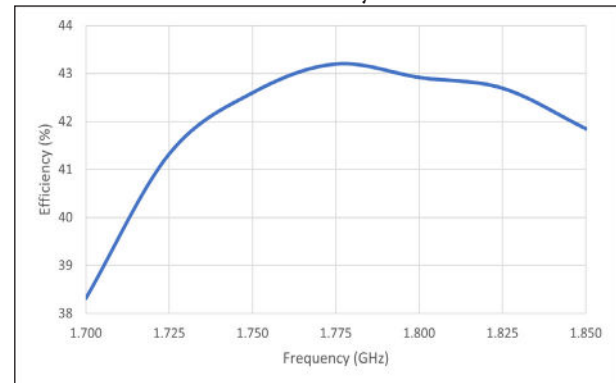

NuPower™ L-10-C01-S01 Power Amplifier

Performance Plots (cont.)

Test Conditions: +28 VDC, +25 °C, $Z_s=Z_L=50 \Omega$, CW, Pmax, 0 dBm Input Power (unless otherwise specified)

Current Consumption

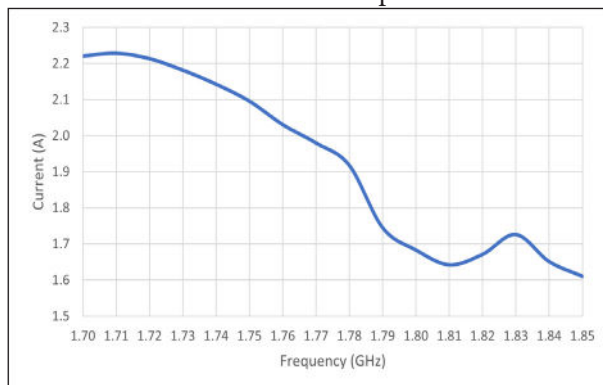

Current Consumption - Power Backoff

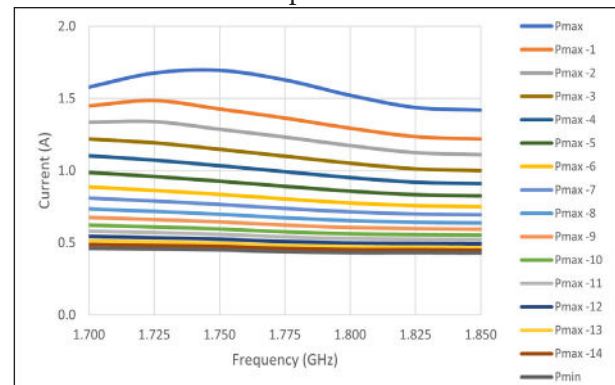

P1dB & P3dB

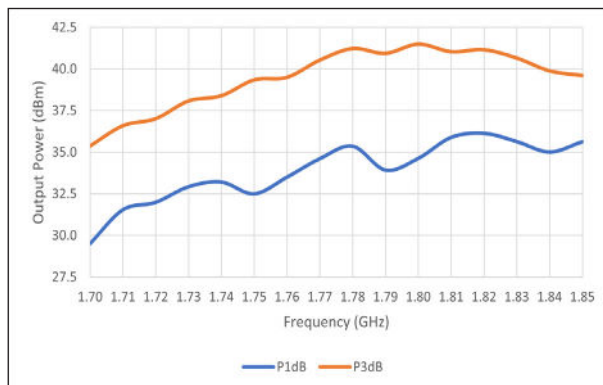

Input VSWR

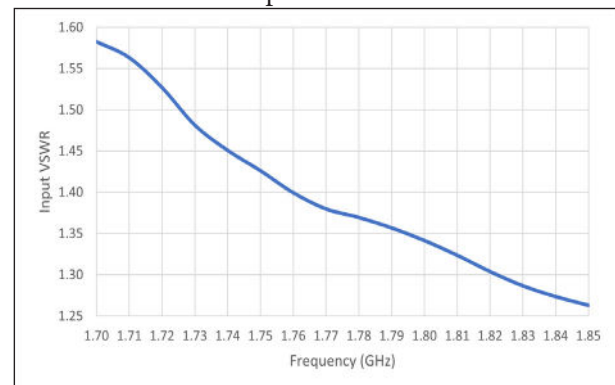

Harmonics

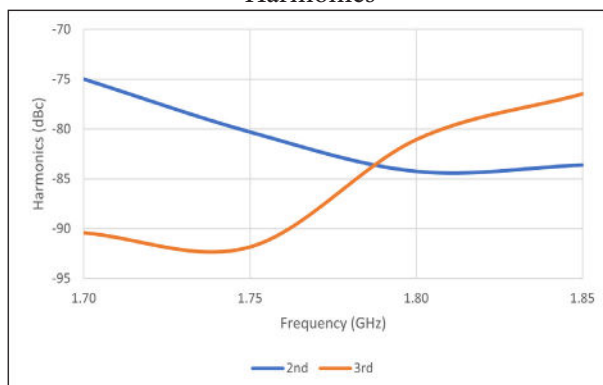

NuPower™ L-10-C01-S01 Power Amplifier

Mechanical Outline

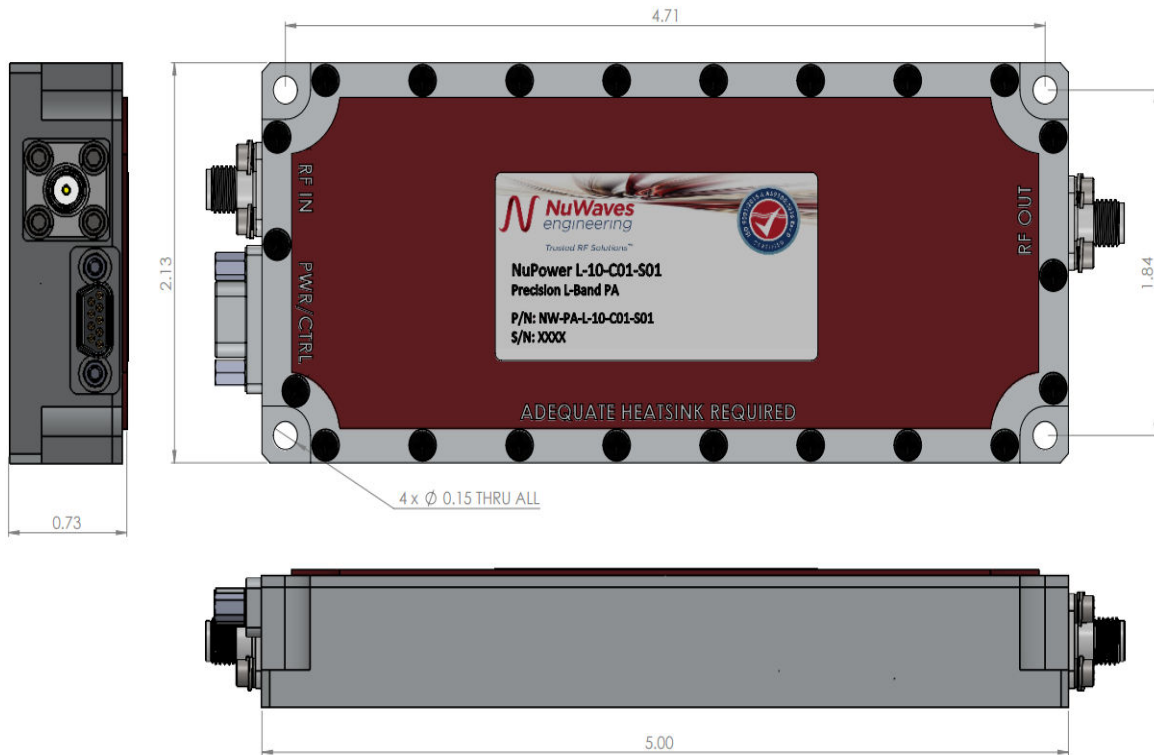

NuPower™ L-10-C01-S01 Power Amplifier

Optional Heatsink

Heatsink & Integrated Fan: HTSK-05

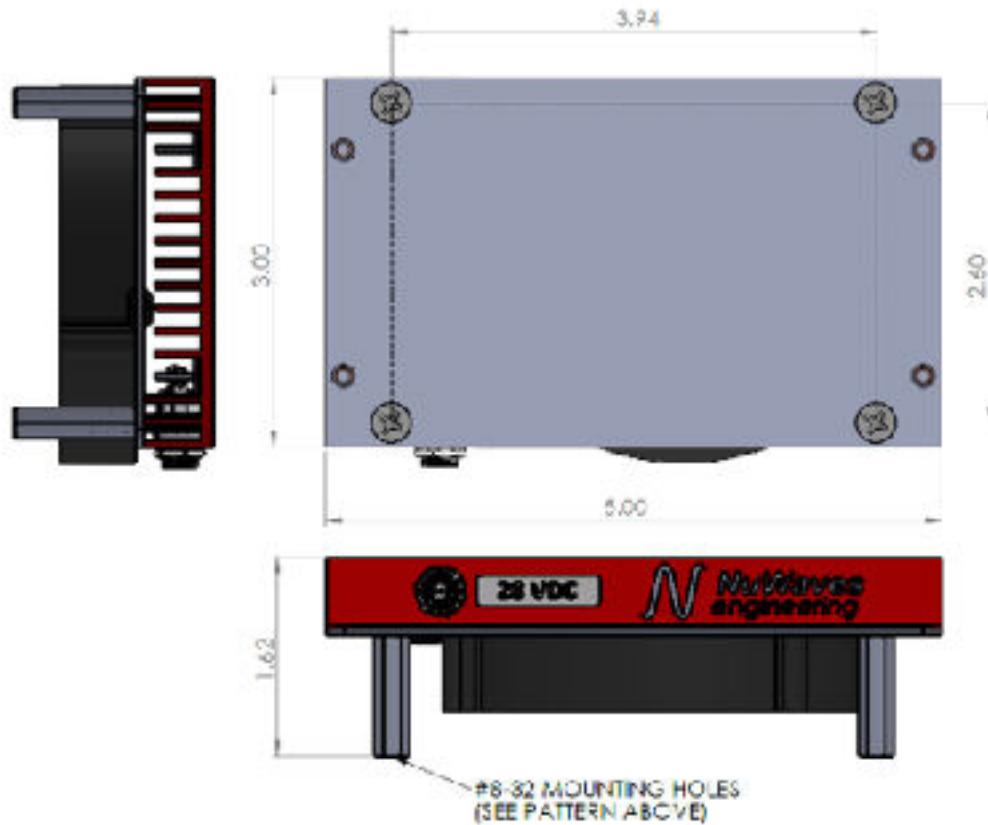

Accessory Part Numbers - Sold Separately

Part Number	Description
NW-FL-05LPLE-2500-SFSF-M01	Harmonic Filter Module
NW-PA-ACC-CB09MJ	Standard Interface Cable Assembly - Flying Leads
NW-PA-ACC-CT09MJ	Upgraded Interface Cable Assembly - Banana Plug Termination
HTSK-05	Heatsink with Integrated Fan

Pinout

Function	I/O	Pin
Ground	I	1, 2, 6
DC Power (+22 to +32 VDC)	I	3, 4, 5
RF Enable 0 V or GND = RF ON +5V or NC = RF OFF	I	9
Rx Data (RS-232)	O	7
Tx Data (RS-232)	I	8

For information on product disposal (end-of-life), please refer to this document:
<https://nuwaves.com/wp-content/uploads/Product-Disposal-End-of-Life.pdf>

Contact NuWaves



NuWaves RF Solutions
 132 Edison Drive
 Middletown, OH 45044

www.nuwaves.com
sales@nuwaves.com
 513.360.0800

