



**NuWaves**  
engineering

Trusted RF Solutions™

## HILNA LS-C026 Low Noise Amplifier

1400 - 1900 MHz  
21 dB Gain

P/N: HILNA-LS-C026



**NuWaves' HILNA LS™-C026 is a high performance, hermetically sealed low noise amplifier within L-band, and designed to achieve high gain while maintaining low noise and a high third-order intercept point.**

This high-performance module delivers 21 dB of gain over the broad range of 1.4 GHz to 1.9 GHz with a noise figure of less than 2 dB and OIP3 of +30 dBm.

The HILNA LS-C026's small form factor (3.2 in<sup>3</sup>) makes it ideal for small communication system installations, co-located to the antenna.

### Features

- Small Form Factor
- Low Noise and High Gain
- High Intercept Point
- Rugged Chassis
- Over-Voltage Protection
- Reverse-Voltage Protection
- Internal Regulator/Active Bias Devices for Stability
- Hermetically Sealed

### Benefits

- Low Level Signal Amplification
- Improved Link Margin
- Ruggedized Chassis for Harsh Environments

### Applications

- RF Front Ends
- High Performance Receivers
- High Gain Block
- Low Noise Transmit Driver
- RF Preamplifier
- RF Repeater
- Base Station LNA

# HILNA LS-C026 Low Noise Amplifier

## Specifications

### Absolute Maximums

Parameter	Rating	Unit
Max Device Voltage	8	V
Max Device Current	300	mA
Max RF Input Power, $Z_L = 50 \Omega$	+20	dBm
Max Operating Temperature	85	°C
Max Storage Temperature	85	°C

Export Classification
EAR99

### Electrical Specifications @ 12 VDC, 25 °C, $Z_S=Z_L=50 \Omega$

Parameter	Symbol	Min	Typ	Max	Unit	Condition
Operating Frequency	BW	1400		1900	MHz	
RF Gain	G	20	21	24	dB	
Reverse Isolation		35	40	50	dB	
VSWR	VSWR		1.4:1	1.8:1		Input
			1.5:1	1.8:1		Output
Noise Figure	NF	1.4	1.6	2.0	dB	
Third Order Intercept Point	OIP3	28	30	33	dBm	
Output Power @ 1dB Compression	P1dB	16	17	19	dBm	
Operating Voltage	VDC	+5	+6	+8	V	
Operating Current	$I_{DD}$		300		mA	@ 12 VDC (typ)

### Mechanical Specifications

Parameter	Value	Unit	Limits
Dimensions	2.50 x 1.75 x 0.75	in	Max
Weight	3.0	oz	Max
RF Input and Output Connectors	SMA Female		
Interface Connector	N/A		

### Environmental Specifications

Parameter	Symbol	Min	Typ	Max	Unit
Operating Temperature (baseplate)	$T_C$	-40		+85	°C
Storage Temperature	$T_{STG}$	-55		+85	°C
Relative Humidity	RH			95	%
Altitude MIL-STD-810F - Method 500.4	ALT			30,000	ft
Vibration / Shock Profile	Random vibration profiles. Maximum flight functional 15min/axis. Maximum flight endurance 1 hr/axis. (3 axes)				

# HILNA LS-C026 Low Noise Amplifier

## Mechanical Outline

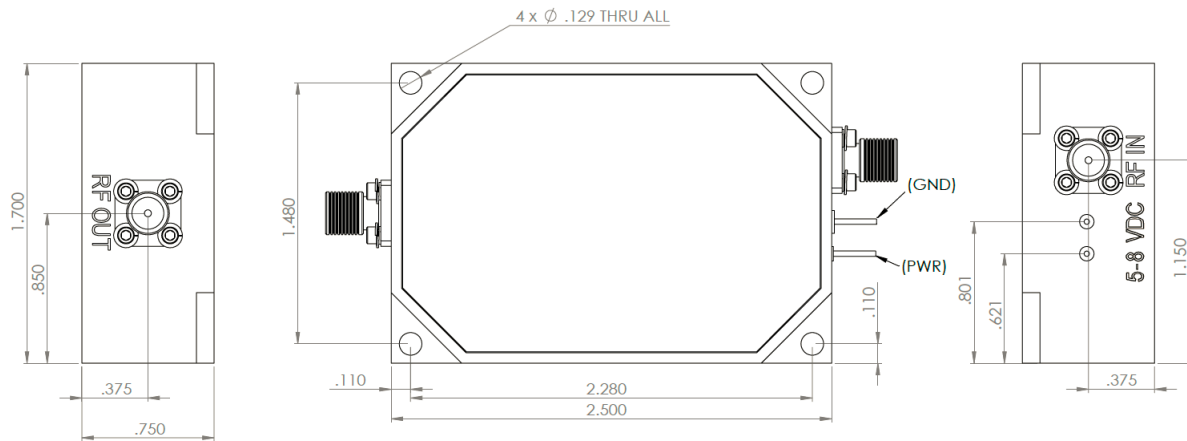

For information on product disposal (end-of-life), please refer to this document:  
<https://nuwaves.com/wp-content/uploads/Product-Disposal-End-of-Life.pdf>

## Contact NuWaves



NuWaves Engineering  
132 Edison Drive  
Middletown, OH 45044

[www.nuwaves.com](http://www.nuwaves.com)  
[product.sales@nuwaves.com](mailto:product.sales@nuwaves.com)  
513.360.0800

**NuWaves**  
engineering

Trusted RF Solutions™